

READ ALL INSTRUCTIONS BEFORE  
ASSEMBLY AND USE.

**KEEP INSTRUCTIONS FOR FUTURE USE.**

**⚠ ADULT ASSEMBLY REQUIRED**

DUE TO THE PRESENCE OF SMALL PARTS  
DURING ASSEMBLY, KEEP OUT OF REACH OF  
CHILDREN UNTIL ASSEMBLY IS COMPLETE.

**Delta**<sup>TM</sup>  
Children's Products

Customer Service:

Web Site: [www.deltachildrenproducts.com](http://www.deltachildrenproducts.com)

Delta Children's Products

114 West 26th Street

New York, NY 10001

Tele. 212-645-9033

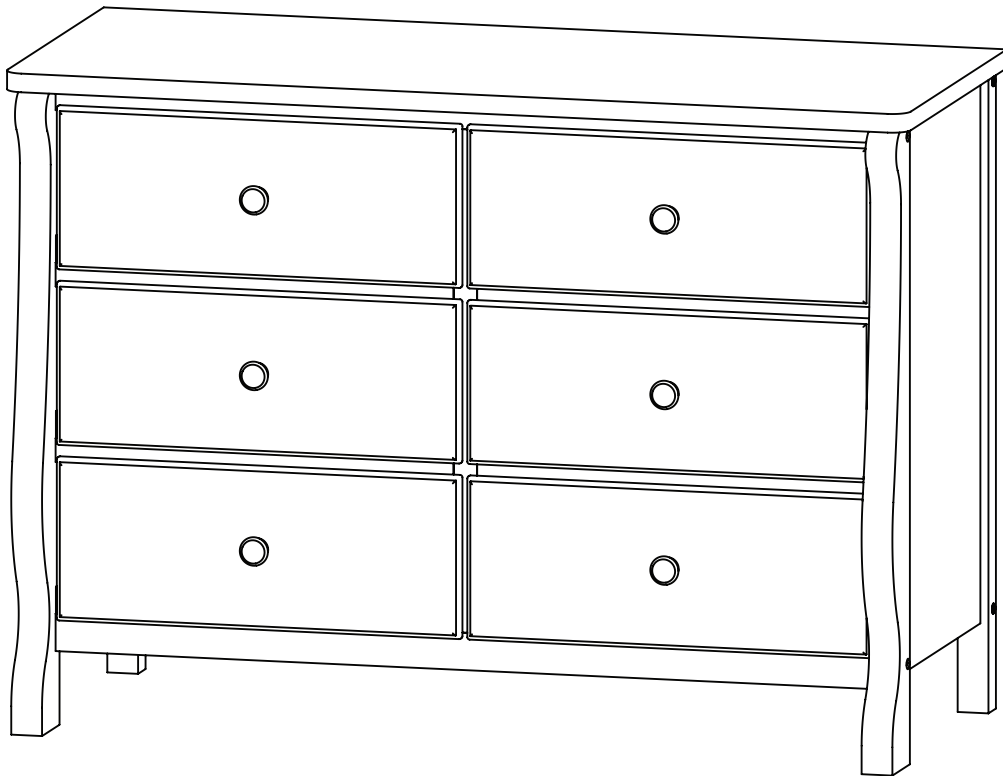

STYLE No: \_\_\_\_\_ -

**607**

COLOR

**A**

REV

**WJ**

FTY

**THIS PRODUCT IS NOT INTENDED FOR INSTITUTIONAL OR COMMERCIAL USE.**

If you have any questions or missing parts, contact us. DO NOT return product parts to the store from where it was purchased before contacting Delta Children's Products Customer Service.

Make sure that all preassemble parts are tight. The appearance of your product may be different from that pictured in this booklet.

To register your product for important safety alerts and updates to your product please visit <http://deltaenterprise.com/register.asp>

## **⚠WARNING:**

**Serious or fatal crushing injuries can occur from furniture tip-over. To help prevent tip-over:**

- Place heaviest items in the lowest drawers.
- Unless specifically designed to accommodate, **do not** set TV's or other heavy objects on the top of this product.
- Never** allow children to climb or hang on drawers, doors, or shelves.
- Never** open more than one drawer at a time.

**Use of tip-over restraints may only reduce, but not eliminate, the risk of tip-over.**

- Always monitor your child's activity when in the nursery.
- Do not** allow standing in drawers.
- Do not** allow standing on top of this product.
- Accessory Items must be securely fastened to this product according to the instructions provided with those items.
- To avoid head injury, do not allow children to play underneath open drawers.
- Do not leave drawers open when not in use.

## **NOTES ON ASSEMBLY:**

- During the assembly process whenever using screws or bolts, check each by placing the screw/bolt on the diagram of the item which is drawn actual size and design. Be sure to use the proper size and shape specified in the instructions.
- To assemble this unit you may be required to place the unit on it's side and face. It is strongly recommended that assembly is done on a soft, non-abrasive surface to avoid damaging the finish.

## **NOTES ON CARE AND MAINTENANCE:**

- **Do not** scratch or chip the finish.
- Inspect the product periodically, contact delta children's products for replacement parts or questions.
- **Do not** store the product or any parts in extreme temperatures and conditions such as a hot attic or a damp, cold basement. These extremes can cause a loss of structural integrity.
- To preserve the luster of the high quality finish on your product, it is recommended to place a doily or felt pad under any items you place on the finish.
- Clean with a damp cloth, then a dry cloth to preserve the original luster and beauty of this fine finish.
- Do not** use abrasive chemicals.
- Do not** spray cleaners directly onto furniture.
- Lift slightly when moving on carpeting to prevent leg breakage.
- Use of a vaporizer near furniture will cause wood to swell and finish to peel.

## **PARTS:**

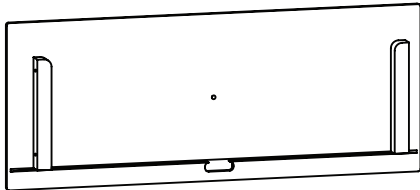

A. DRAWER FRONT - LEFT DRAWER (x3)

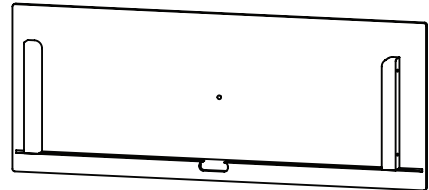

B. DRAWER FRONT - RIGHT DRAWER (x3)

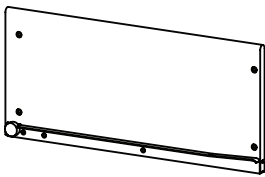

C. LEFT DRAWER SIDE (x6)

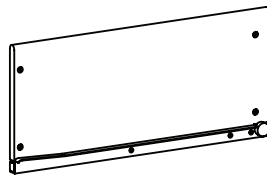

D. RIGHT DRAWER SIDE (x6)

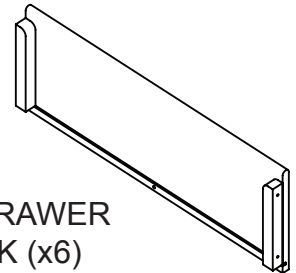

E. DRAWER BACK (x6)

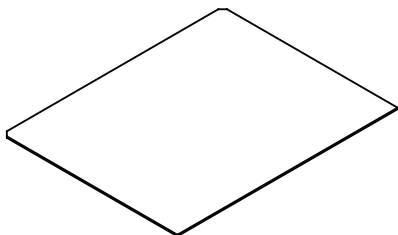

F. DRAWER BOTTOM (x6)

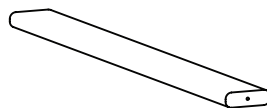

G. DRAWER SUPPORT (x6)

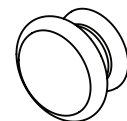

H. KNOB (x6)

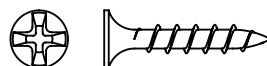

J. DRAWER ASSEMBLY SCREW (x54)



K. KNOB SCREW (x6)

**BOLTS AND SCREWS ARE SHOWN FULL SIZE.**

PARTS-CONTINUED:

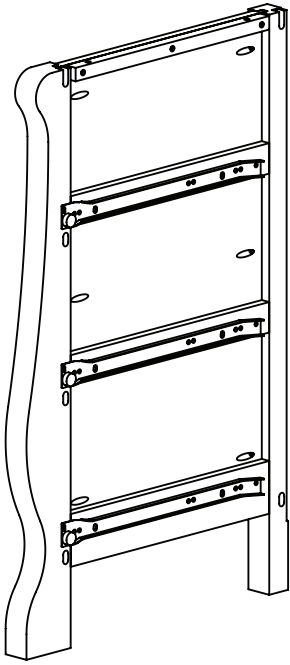

L. LEFT SIDE PANEL (x1)

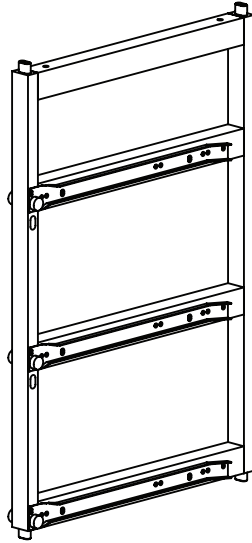

M. CENTER FRAME (x1)

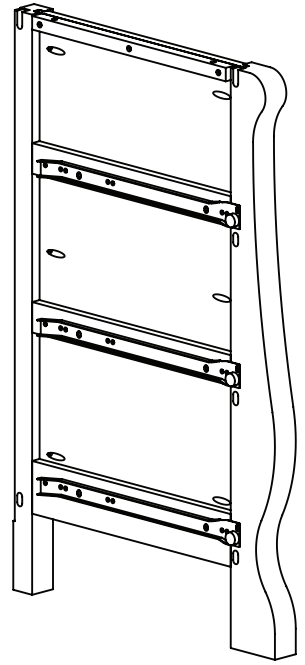

N. RIGHT SIDE PANEL (x1)

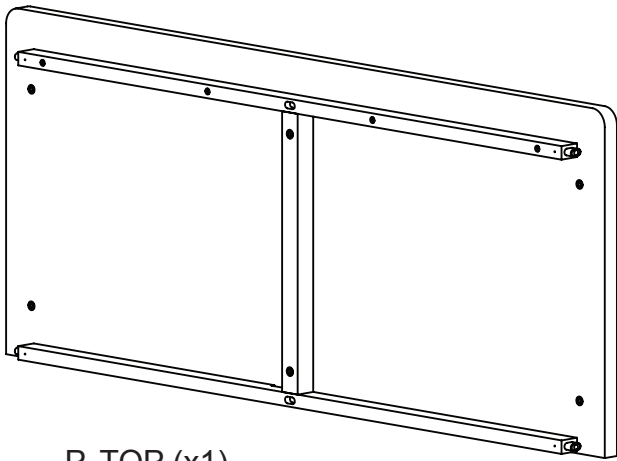

P. TOP (x1)

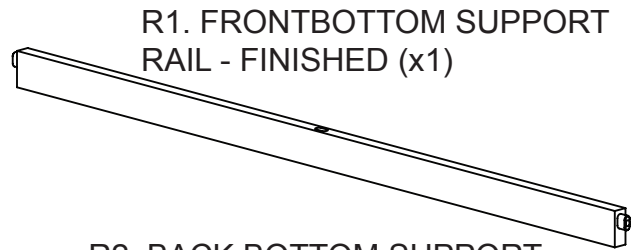

R1. FRONTBOTTOM SUPPORT RAIL - FINISHED (x1)

R2. BACK BOTTOM SUPPORT RAIL - UNFINISHED (x1)

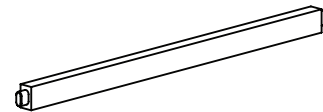

S. UPPER SUPPORT RAIL (x4)

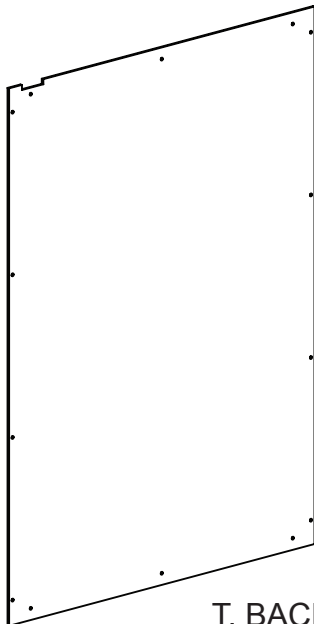

T. BACK PANEL (x2) **BOLTS AND SCREWS ARE SHOWN FULL SIZE.** 3



V. BACK PANEL SCREW (x28)

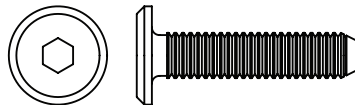

W. SHORT BOLT(x4)

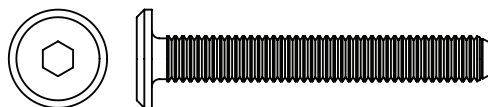

X. LONG BOLT(x10)



M4 ALLEN WRENCH SUPPLIED

# SECTION 1: DRAWER ASSEMBLY

## STEP 1

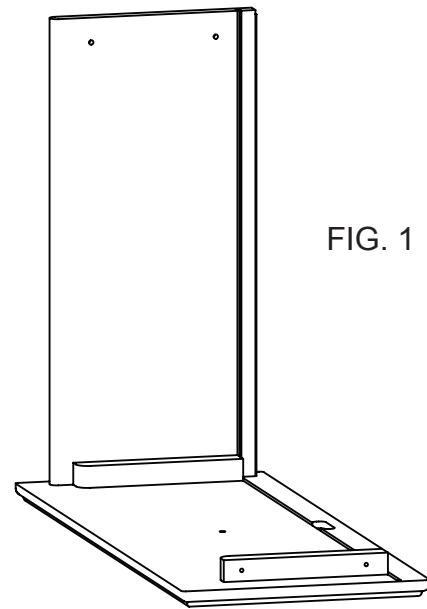
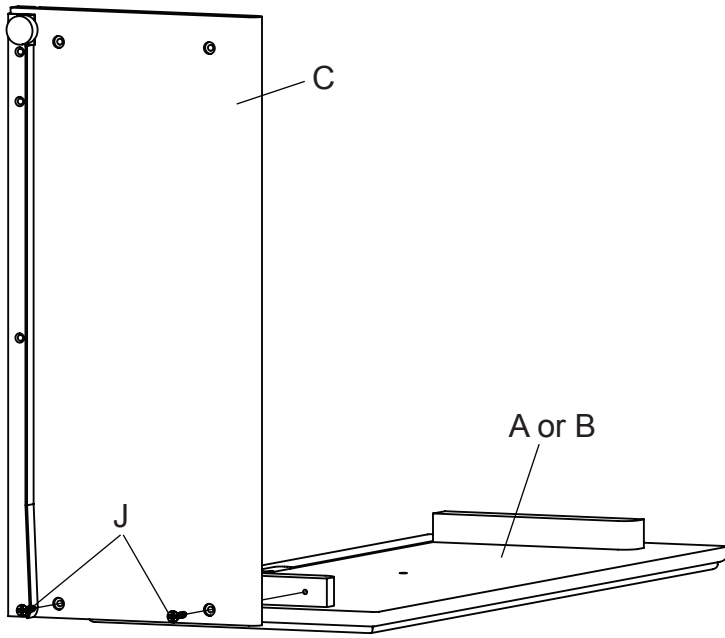

1. ATTACH THE LEFT DRAWER SIDE (PART C) TO THE DRAWER FRONT (PART A OR B) USING (2) DRAWER ASSEMBLY SCREWS (PART J), TIGHTEN WITH THE PHILLIPS SCREWDRIVER. BE SURE THE GROOVE IN THE BOTTOM OF THE PARTS LINE UP. SEE FIGURE 1. THE METAL DRAWER GUIDE MUST BE TO THE OUTSIDE. REPEAT WITH THE RIGHT DRAWER SIDE (PART D)

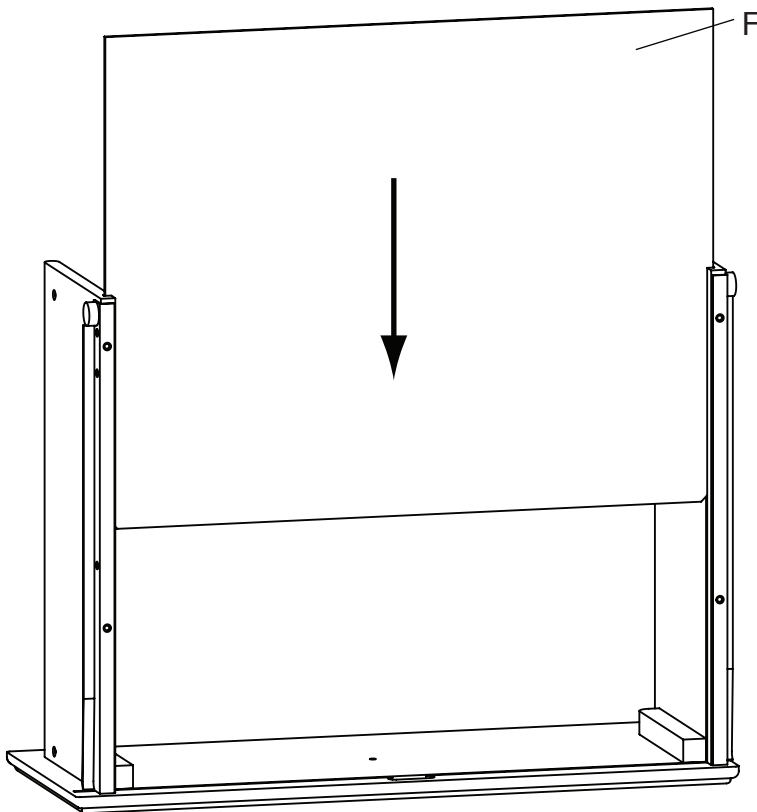

2. SLIDE THE DRAWER BOTTOM (PART F) INTO THE GROOVES ON THE DRAWER SIDES, UNTIL IT IS IN THE GROOVE ON THE DRAWER FRONT. BE SURE THE NOTCHED CORNERS ARE TOWARDS THE DRAWER FRONT.

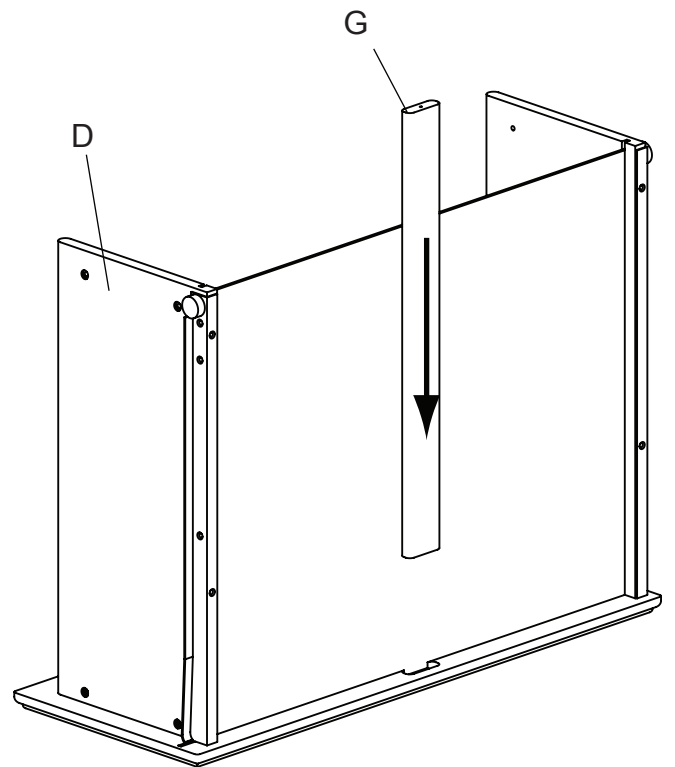

3. INSERT THE DRAWER SUPPORT (PART G) INTO THE CUTOUT IN THE DRAWER FRONT. BE SURE THE END OF THE DRAWER SUPPORT WITH THE PRE-DRILLED HOLE IS TO THE BACK.

# SECTION 1: DRAWER ASSEMBLY

## STEP 2

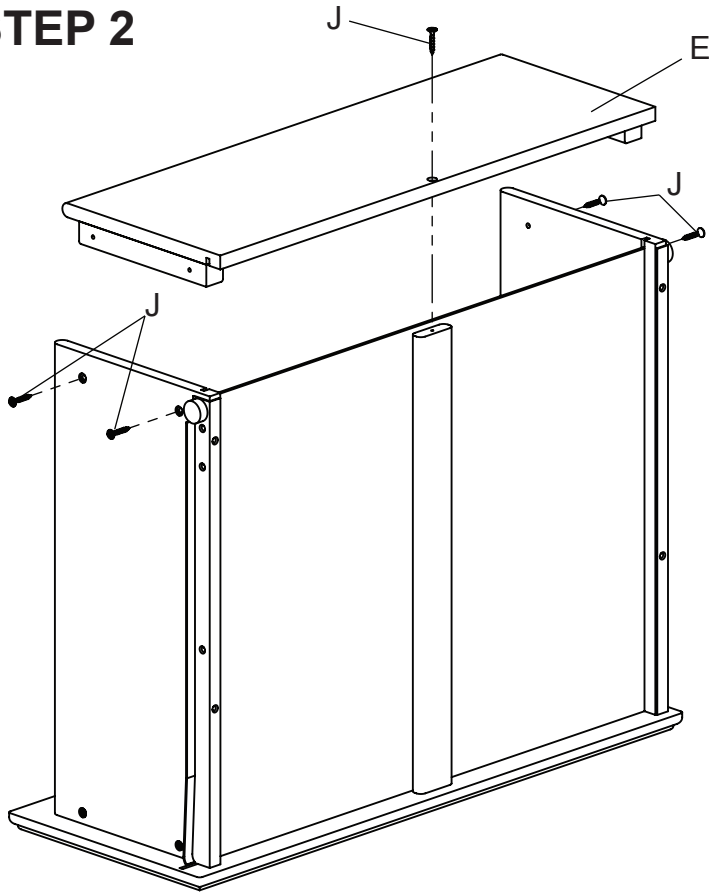

1. ATTACH THE DRAWER BACK (PART E) TO THE DRAWER ASSEMBLY USING (5) DRAWER ASSEMBLY SCREWS (PART J), TIGHTEN WITH THE PHILLIPS SCREWDRIVER. BE SURE THE DRAWER BOTTOM IS IN THE GROOVE ON THE DRAWER BACK BEFORE ATTACHING ANY SCREWS.

2. ATTACH THE KNOB (PART H) TO THE DRAWER ASSEMBLY USING (1) KNOB SCREW (PART K) TIGHTEN WITH THE PHILLIPS SCREWDRIVER.

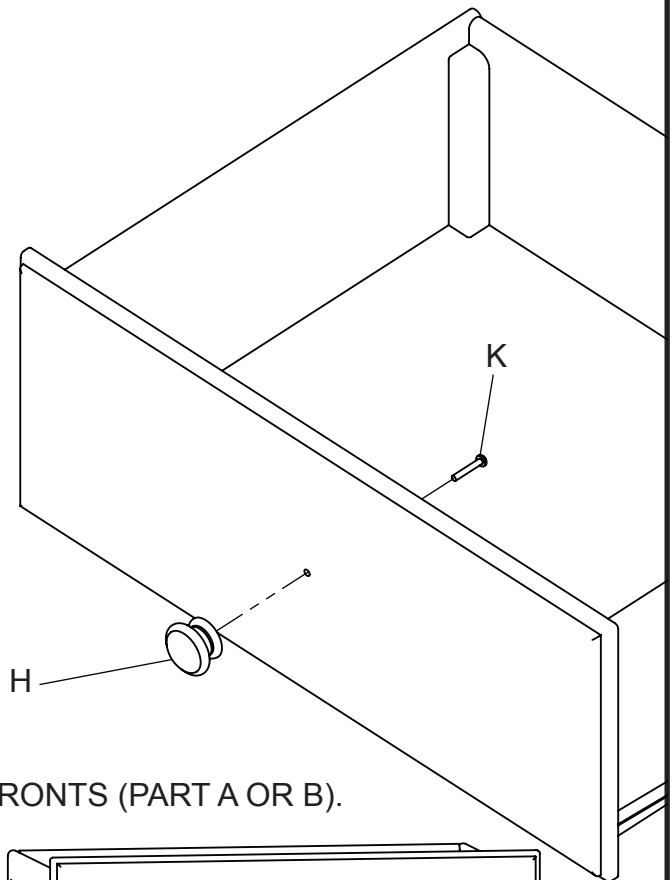

3. REPEAT FOR ALL OTHER DRAWER FRONTS (PART A OR B).

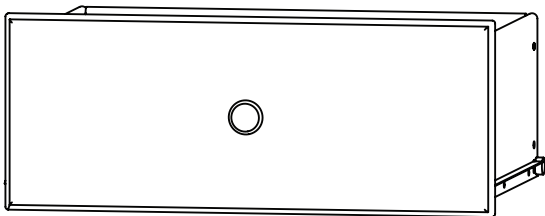

ASSEMBLED LEFT DRAWER (x3)

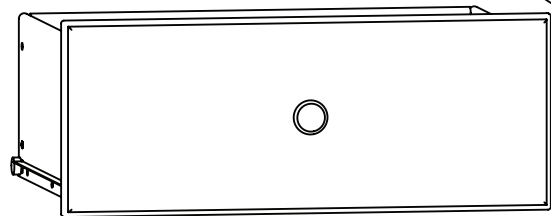
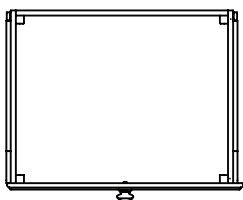

ASSEMBLED RIGHT DRAWER (x3)

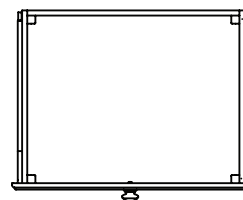

## SECTION 2: CASE ASSEMBLY

### STEP 1

FOR CASE ASSEMBLY PLACE THE TOP (PART P) ON A STABLE, NON-ABRASIVE SURFACE, SUCH AS A BLANKET ON THE FLOOR.

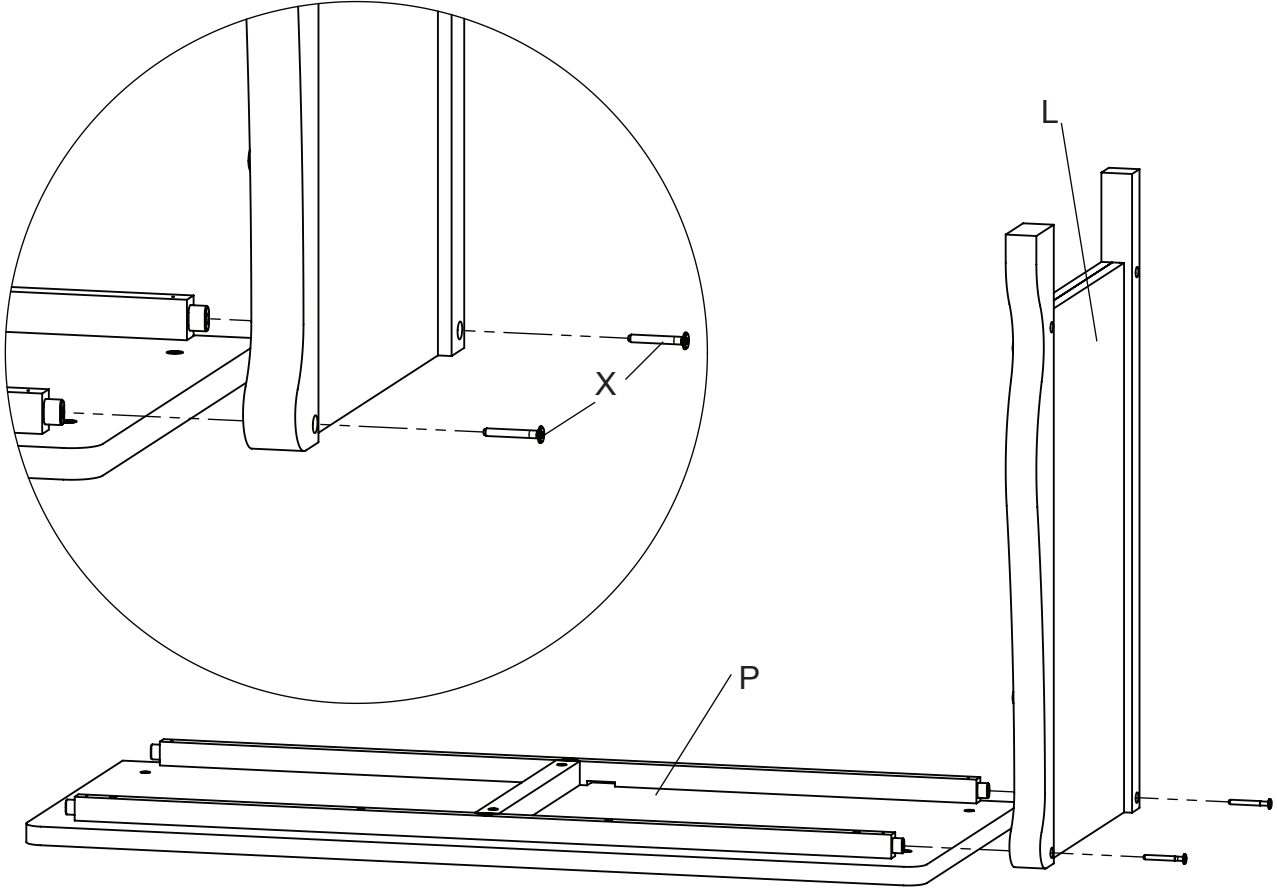

1. ATTACH THE LEFT SIDE PANEL (PART L) TO THE TOP (PART P) USING (2) LONG BOLTS (PART X), TIGHTEN WITH THE M4 ALLEN WRENCH.

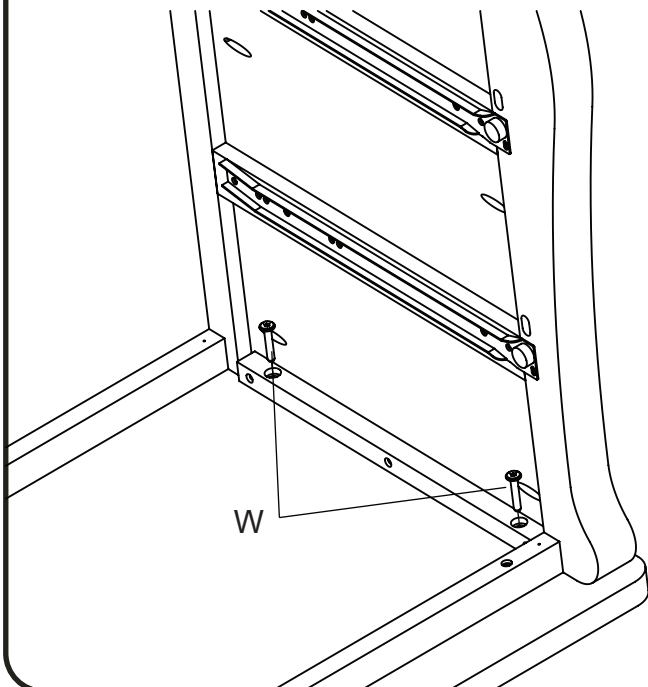

2. FINISH THE ATTACHMENT OF THE LEFT SIDE PANEL BY INSTALLING (2) SHORT BOLTS (PART W) AS SHOWN, TIGHTEN WITH THE M4 ALLEN WRENCH.

## SECTION 2: CASE ASSEMBLY

### STEP 2

1. INSERT (2) UPPER SUPPORT RAILS (PART S) INTO THE SLOTS IN THE FRONT POST OF THE SIDE PANEL. FINISHED PANEL MUST FACE FRONT.

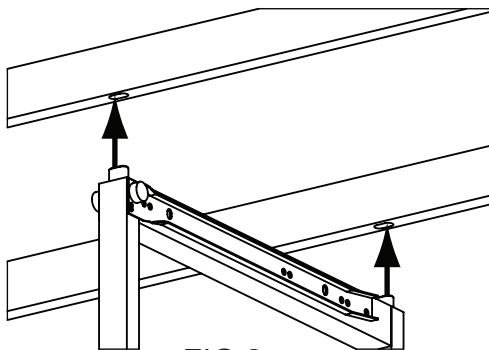

FIG 2

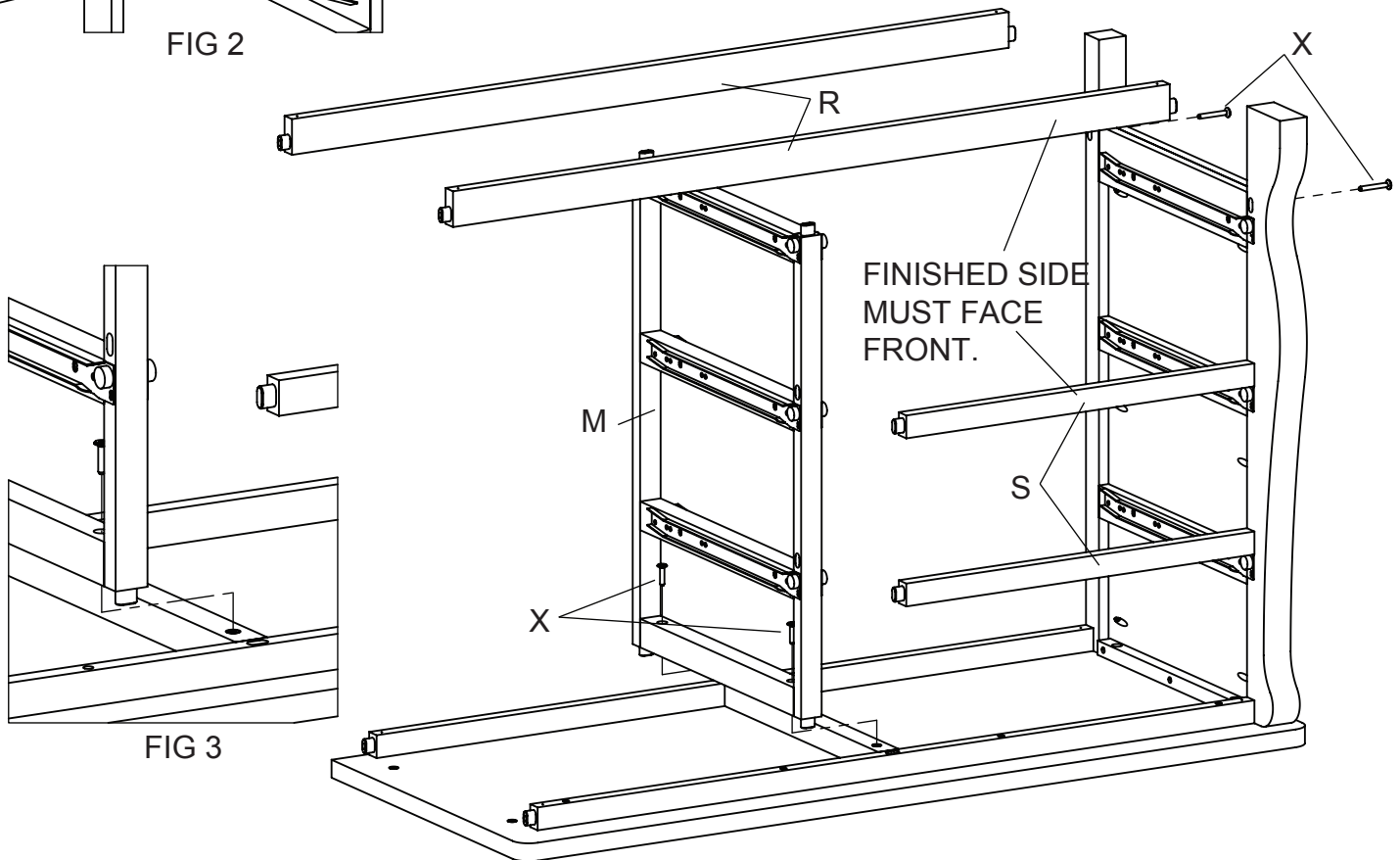
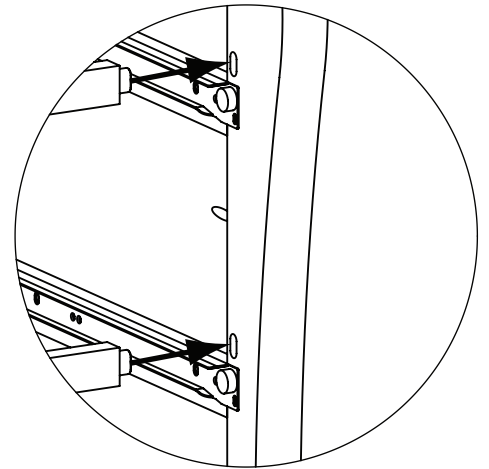

FIG 3

2a. INSERT THE TABS ON THE END OF THE CENTER FRAME (PART M) INTO THE SLOTS IN THE RAILS ON THE TOP. BE SURE THE DRAWER GUIDES ARE IN THE SAME DIRECTION AS THOSE ON THE SIDE PANEL. INSERT THE UPPER SUPPORT RAILS INTO THE SLOTS ON THE CENTER FRAME. TAKE CARE NOT TO SCRATCH THE FINISH.

2b. INSTALL (2) BOTTOM SUPPORT RAILS (PART R) BY INSERTING THE TABS ON THE BOTTOM SUPPORT RAILS INTO THE SIDE PANEL AND INSERTING THE TABS ON THE CENTER FRAME INTO THE BOTTOM SUPPORT RAILS. SEE FIGURE 2. FINISHED SIDE MUST FACE FRONT.

2c. INSTALL (2) LONG BOLTS (PART X) THROUGH THE SIDE PANEL. TIGHTEN WITH THE M4 ALLEN WRENCH.

2d. INSTALL (2) LONG BOLTS (PART X) THROUGH THE CENTER FRAME, TIGHTEN WITH THE M4 ALLEN WRENCH. SEE FIGURE 3.

## SECTION 2: CASE ASSEMBLY

### STEP 3

1. INSERT (2) UPPER SUPPORT RAILS (PART S) INTO THE SLOTS IN THE FRONT POST OF THE CENTER FRAME. FINISHED SIDE MUST FACE FRONT.

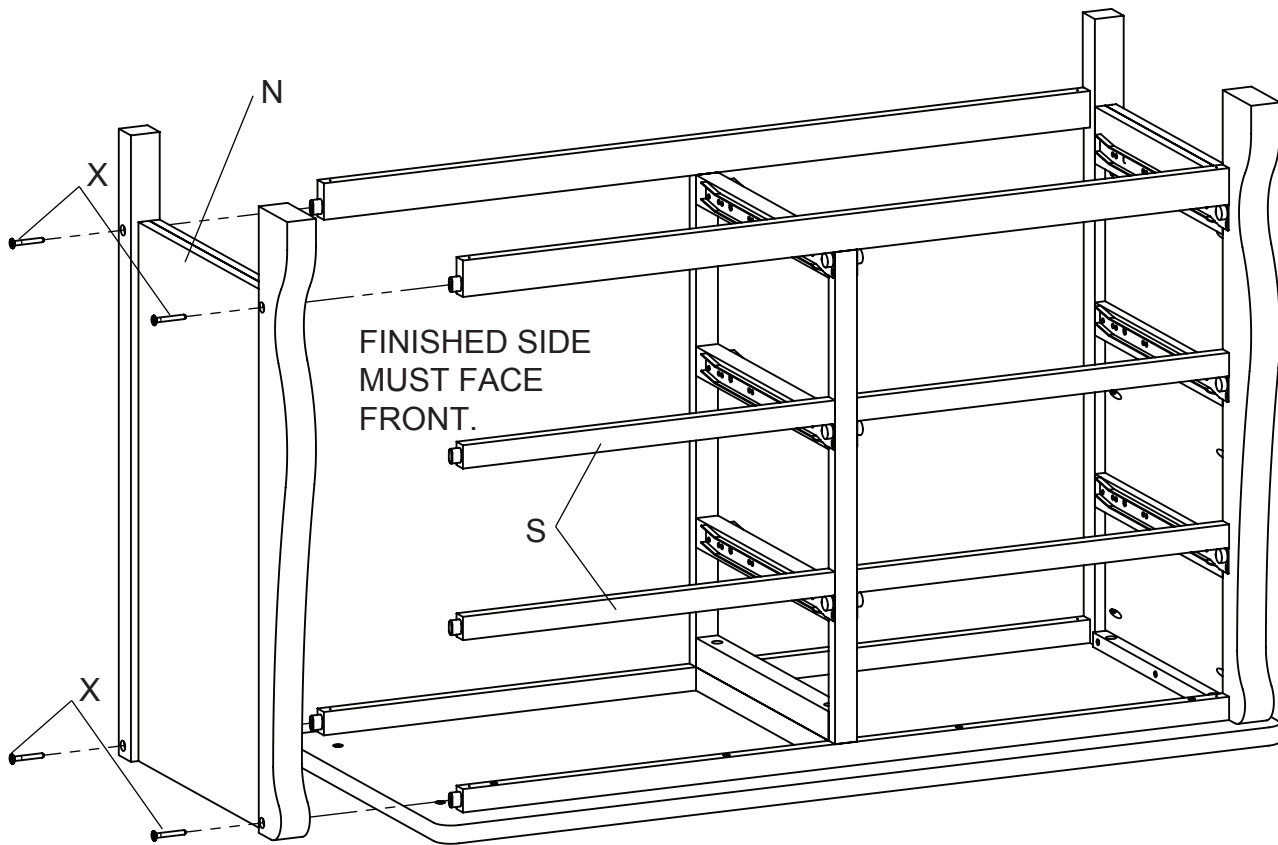
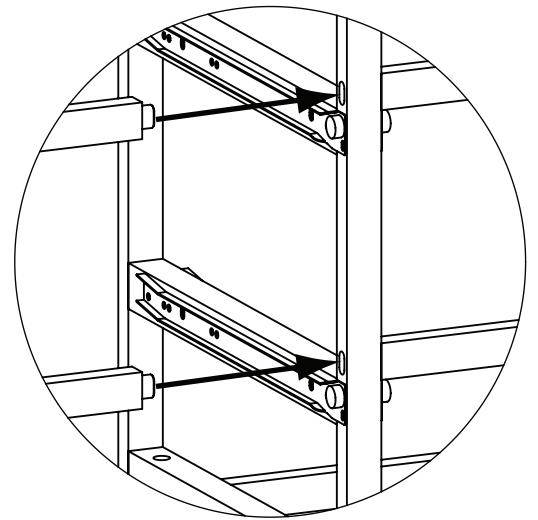

2a. INSTALL THE RIGHT SIDE PANEL (PART N) BY ALIGNING THE TABS ON ALL OF THE INSTALLED PIECES WITH THE SLOTS IN THE SIDE PANEL. IT IS TYPICALLY EASIEST TO START WHERE THE SIDE PANEL MEETS THE TOP AND WORK TO THE BOTTOM SUPPORT RAILS.

2b. INSTALL (4) LONG BOLTS (PART X) THROUGH THE SIDE PANEL, TIGHTEN WITH THE M4 ALLEN WRENCH.

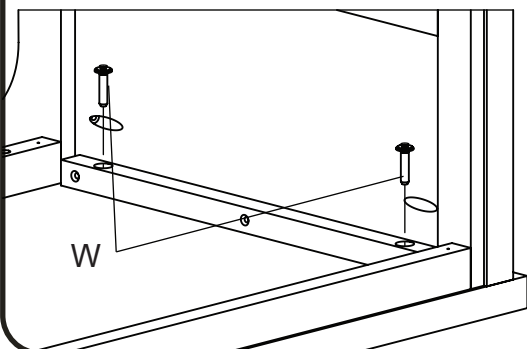

3. FINISH THE ATTACHMENT OF THE RIGHT SIDE PANEL BY INSTALLING (2) SHORT BOLTS (PART W) AS SHOWN, TIGHTEN WITH THE M4 ALLEN WRENCH.



## SECTION 2: CASE ASSEMBLY

### STEP 4

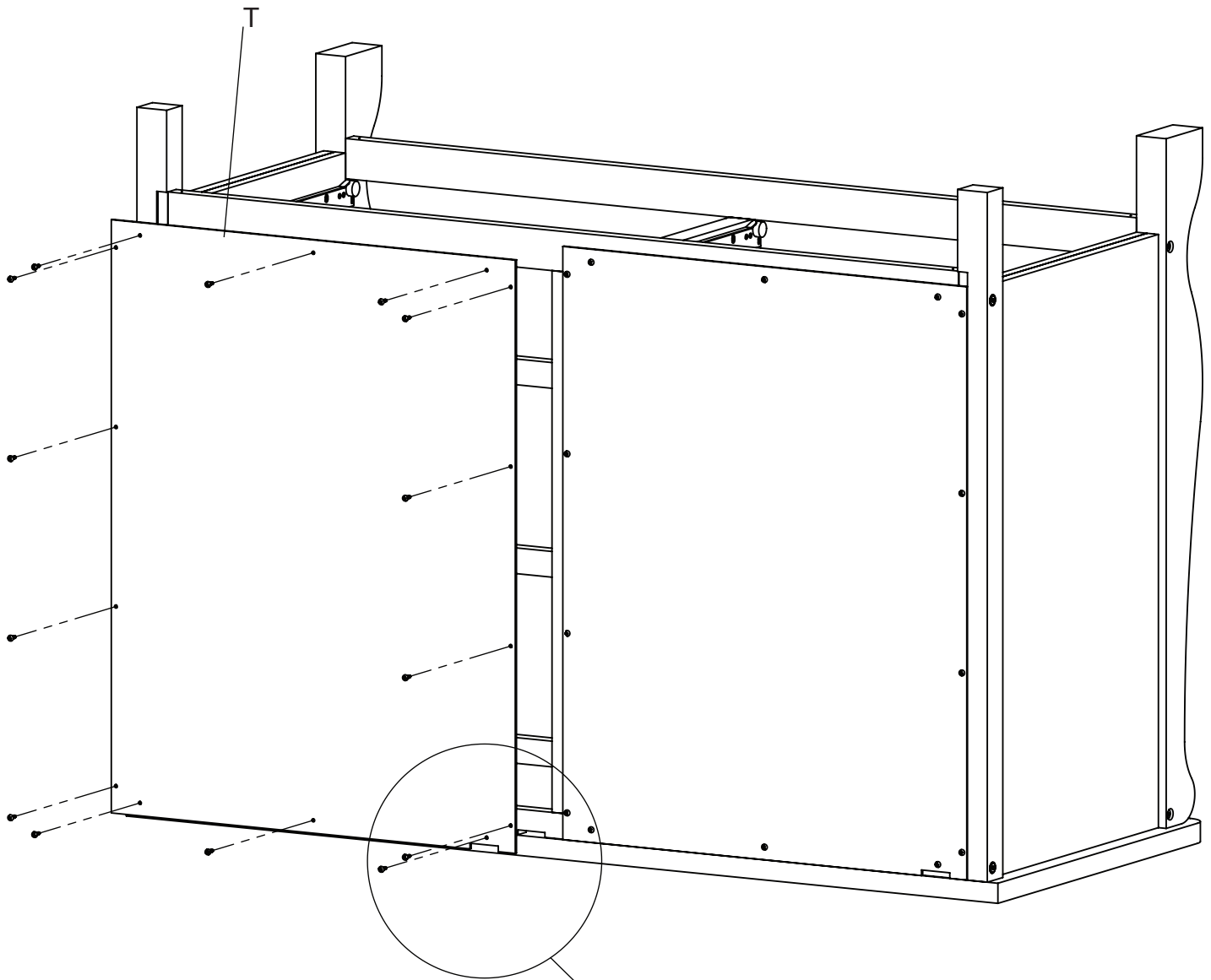

INSTALL THE BACK PANELS (PART T) USING (14) BACK PANEL SCREWS (PART V) FOR EACH. TIGHTEN WITH THE PHILLIPS SCREWDRIVER. ABOVE ONE BACK PANEL IS SHOWN INSTALLED. THE SMALL NOTCH IN THE BACK PANEL MUST BE INSTALLED AS SHOWN AS CAN BE SEEN IN FIGURE 3, THE NOTCH LINES UP WITH A NOTCH IN THE RAIL PRE-ASSEMBLED TO THE TOP. THIS WILL ALLOW ATTACHMENT OF THE WALL STRAP - SEE KIT FOR INSTRUCTIONS ON USE.

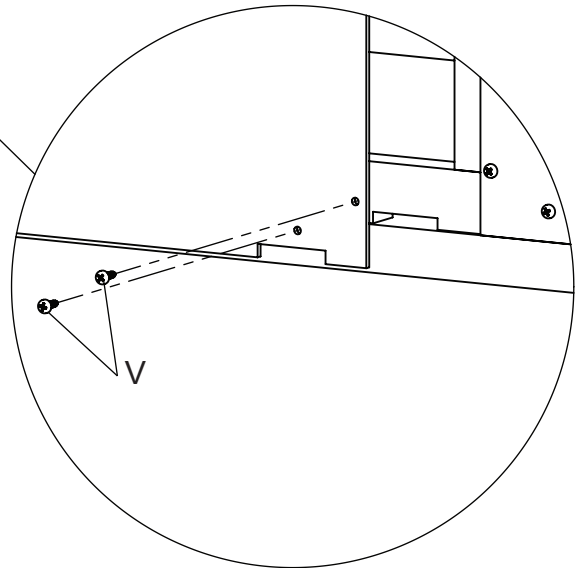

## SECTION 2: CASE ASSEMBLY

### STEP 5

SET THE CASE UPRIGHT (FEET ON THE GROUND) THE CASE IS HEAVY, THIS MAY REQUIRE (2) PEOPLE.

INSTALL THE DRAWERS BY PLACING THE WHEELS ON THE DRAWER BEHIND THE WHEELS ON THE CABINET. PUSH THE DRAWER IN.

BE SURE THAT THE ASSEMBLED LEFT DRAWERS GO ON THE LEFT SIDE AND THE ASSEMBLED RIGHT DRAWERS GO ON THE RIGHT SIDE. SEE FIGURE 4.

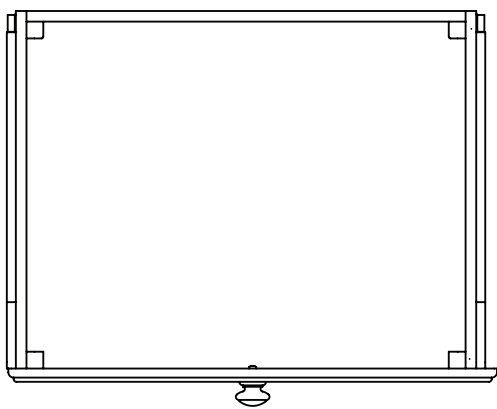
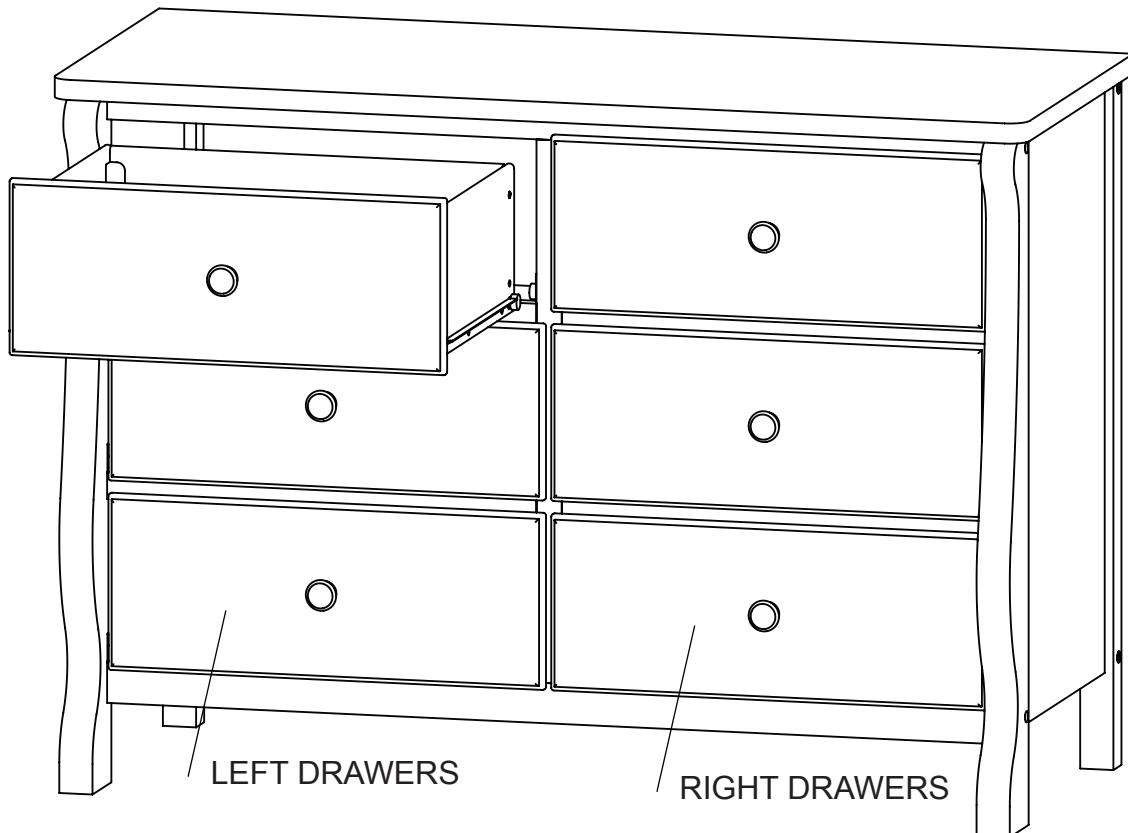

ASSEMBLED LEFT DRAWER (x3)

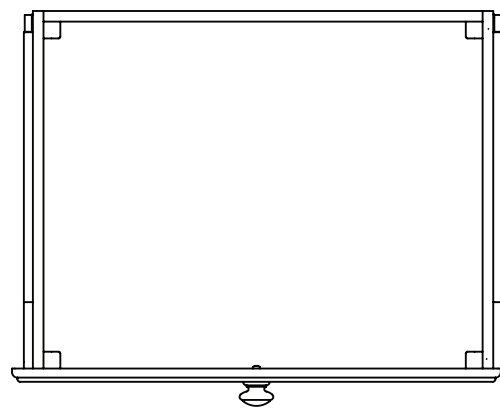

ASSEMBLED RIGHT DRAWER (x3)

FIG. 4 - NOTE THAT THE DRAWER FRONT IS SLIGHTLY OFF-CENTER ON THE DRAWER BOX, THIS IS INTENTIONAL.

## FINAL ASSEMBLY

THE SLOT FOR ATTACHING THE WALL STRAP  
IS LOCATED BEHIND THIS DRAWER

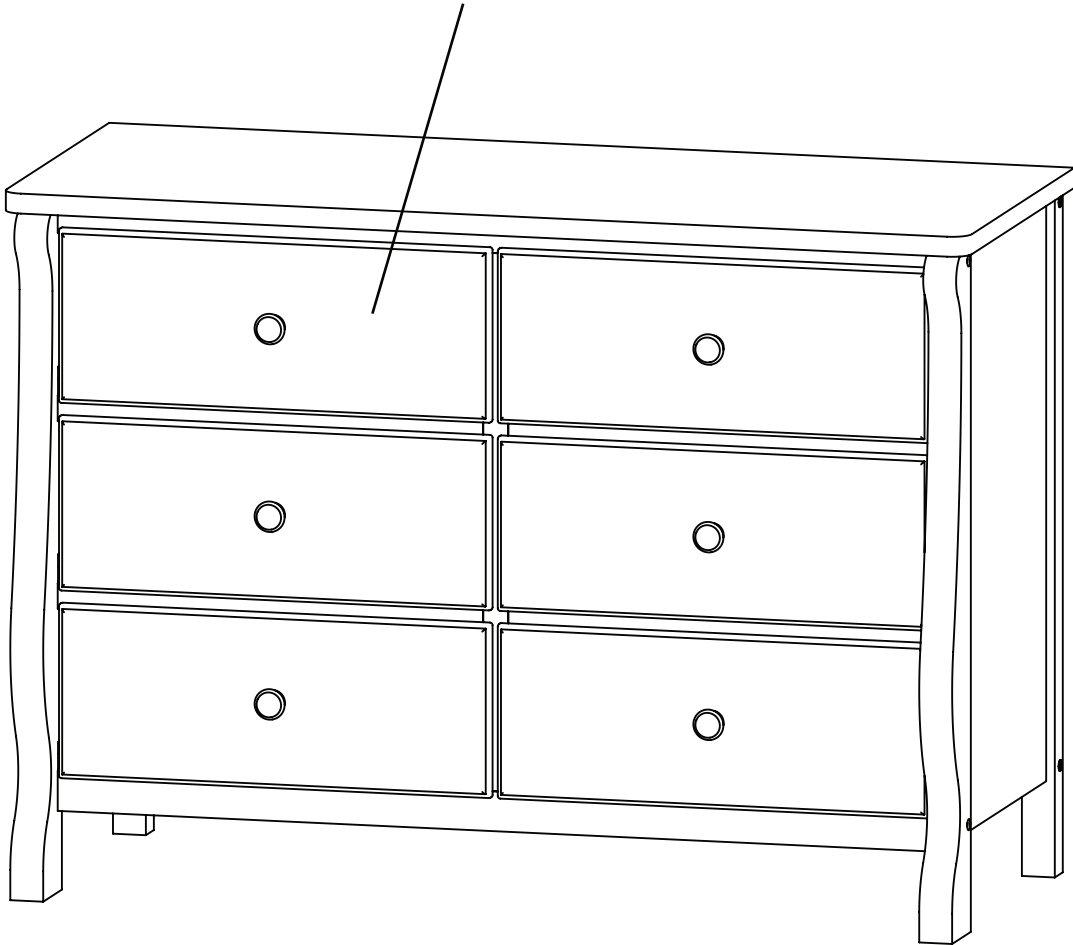

TO SECURE THE DRESSER TO THE WALL, PLEASE REFER TO THE  
INSTRUCTIONS IN THE PROVIDED WALL STRAP KIT.



**Children's Products**

Customer Service:

Web Site: [www.deltachildrenproducts.com](http://www.deltachildrenproducts.com)

Delta Children's Products

114 West 26th Street

New York, NY 10001

Tele.212-645-9033

**Warranty:** This Delta product is warranted to be free from defects for a period of 90 days from the date of purchase under normal use. This warranty extends only to the original retail purchaser and is valid only when supplied with proof of purchase, or if received as a gift, when the registration is on file with Delta.

To register your product for important safety alerts and updates to your product please visit <http://deltaenterprise.com/register.asp>

Please do not return this item to the store before contacting us about missing parts or with any questions.

In the event that you need to contact our customer service department please have the Style Number and Lot Number available. To report a problem, please log on to [www.deltachildrenproducts.com](http://www.deltachildrenproducts.com) and click the Customer Service Tab, or log on to [www.deltaenterprise.com/customer\\_service.asp](http://www.deltaenterprise.com/customer_service.asp), or contact us by phone at (212) 645-9033.

Use the space below to make note of those numbers. They can be found on the label on the back of the product.

Style No.: \_\_\_\_\_

Lot No. : \_\_\_\_\_

Pack Date: \_\_\_\_\_

Date of Purchase: \_\_\_\_\_ (you should also keep your receipt)