

JVC

Emerald FT/FL Series

QUICK START GUIDE

IMPORTANT SAFETY INFORMATION



The lightning flash with arrowhead symbol, within an equilateral triangle, is intended to alert the user to the presence of uninsulated dangerous voltage with the product's enclosure that may be of sufficient magnitude to constitute a risk of electric shock.



The exclamation point within an equilateral triangle is intended to alert the user to the presence of important operating and maintenance (servicing) instructions in the literature accompanying the appliance.

- Read and follow all these instructions.
- Heed all warnings.
- Do not use this device near water.
- Clean only with dry cloth.
- Do not block any ventilation openings. Install in accordance with manufacturer's instructions.
- Do not install near any heat sources such as radiators, heat registers, stoves, or other heat-generation devices.
- Do not defeat the safety purpose of the polarized or grounding-type plug. A polarized plug has two blades with one wider than the other. A grounding-type plug has two blades and a third grounding prong. The wide blade or the third prong is provided for your safety. If the provided plug does not fit into your outlet, consult an electrician for replacement of the obsolete outlet.
- Protect the power cord from being walked on or pinched, particularly at plugs, convenience receptacles, and the point where they exit from the device.
- Only use attachments/accessories specified by the manufacturer.
- Use only with the cart, stand, tripod, bracket, or table specified by the manufacturer, or sold with the apparatus. When a cart is used, use caution when moving the cart/apparatus combination to avoid injury from tip-over.
- Unplug this apparatus during lightning storms or when unused for long periods of time.
- Refer all servicing to qualified service personnel. Servicing is required when the apparatus has been damaged in any way, such as power supply cord or plug is damaged, liquid has been spilled or objects have fallen into the apparatus, the apparatus has been exposed to rain or moisture, does not operate normally, or has been dropped.
- Apparatus should not be exposed to dripping or splashing, and objects filled with



liquids, such as vases, should not be placed on the apparatus.

- An outside antenna system should not be located in the vicinity of overhead power lines or other electric light or power circuits, or where it can fall into such power lines or circuits. When installing an outside antenna system, extreme care should be taken to keep from touching such power lines or circuits, as contact with them might be fatal.
- Do not overload wall outlets and extension cords, as this can result in a risk of fire or electric shock.
- Do not push objects through any openings in this unit as they may touch dangerous voltage points or short out parts that could result in fire or electric shock. Never spill or spray any type of liquid into the unit.
- If an outside antenna or cable system is connected to the unit, be sure the antenna or cable system is grounded to provide some protection against voltage surges and built-up static charges, Section 810 of the National Electrical Code, ANSI/NFPA 70, provides information with respect to proper grounding practices.
- When replacement parts are required, be sure the service technician uses replacement parts specified by the manufacturer or those that have the same characteristics as the original part. Unauthorized substitutions may result in fire, electric shock, or other hazards.
- Upon completion of any service or repairs to this unit, ask the service technician to perform safety checks to determine that the unit is in proper operating condition.
- When you connect the product to other equipment, turn off the power and unplug all of the equipment from the wall outlet.
- Sudden high volume sound may cause hearing or speaker damage. When you use headphones (if the unit is equipped with a headphone jack), keep the volume at a moderate level.

CHECK MATERIALS IN PACKAGE

Check if the following items are included in your package.

LED TV



Remote Control



Batteries

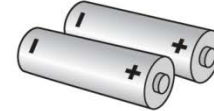

Quick Start Guide



Power Cord



DOWNLOAD FULL VERSION USER MANUAL

<http://jvc-tv.com>

*Images shown here are only for illustration purpose.

REMOTE CONTROL

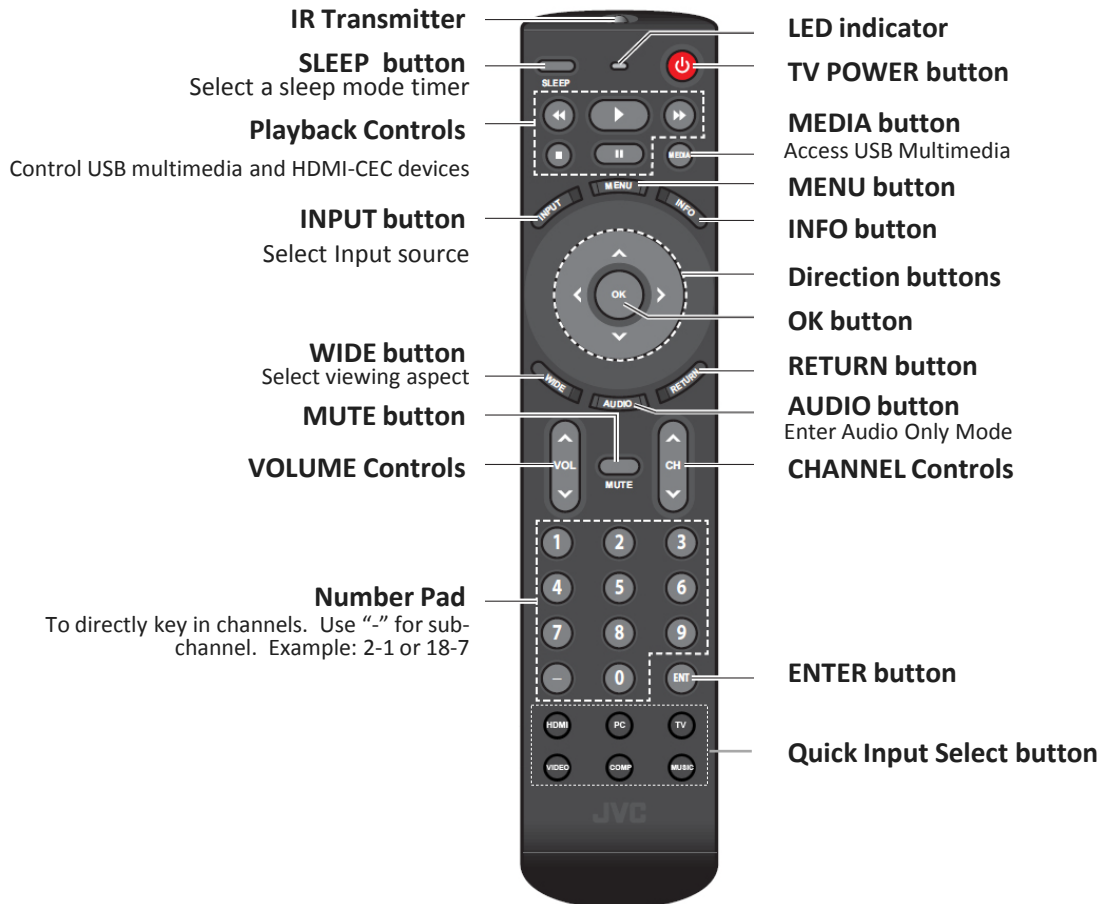

FRONT VIEW



Power Indicator & Remote Sensor

*Image shown here is only for illustration purpose.

REAR VIEW

*EM32FL

*EM39FT

*Image shown here is only for illustration purpose.

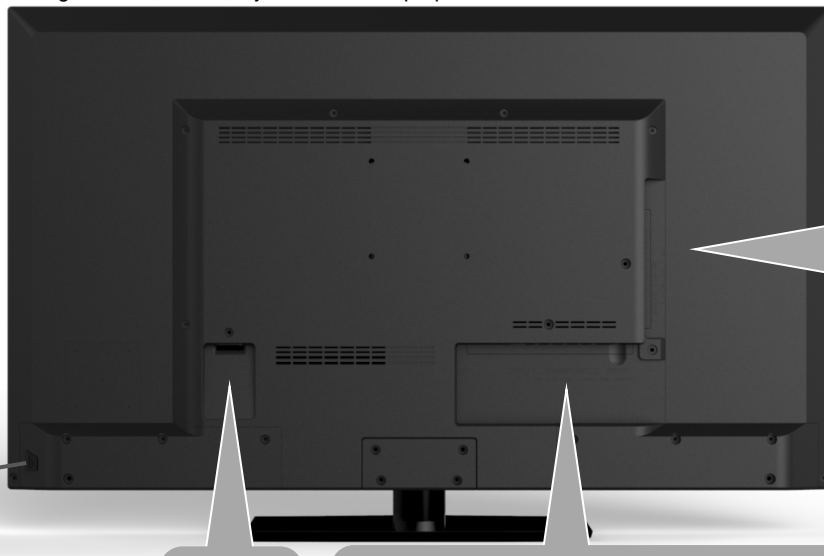

Power / Multi-Function Button



USB

HDMI / MHL

(*No charge supported while TV is OFF.)

Digital Optical Out

Audio Out



AC Power

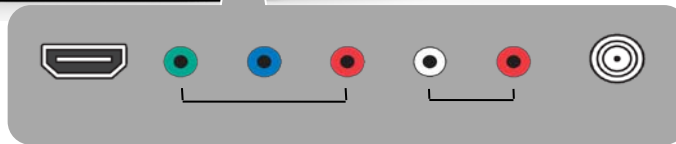

HDMI-1

Component /
Video Input

Audio Input /
Music Port

Antenna
Input

Power / Multi-Function Button Operation:

- Press the button to show Quick Control Menu and switch between options
- Press and hold the button to select highlighted option
- To power off TV, press and hold the button while Quick Control Menu is not on screen

REAR VIEW

*Image shown here is only for illustration purpose.

- *EM42FT
- *EM48FT
- *EM55FT
- *EM65FT

Power and Function Buttons

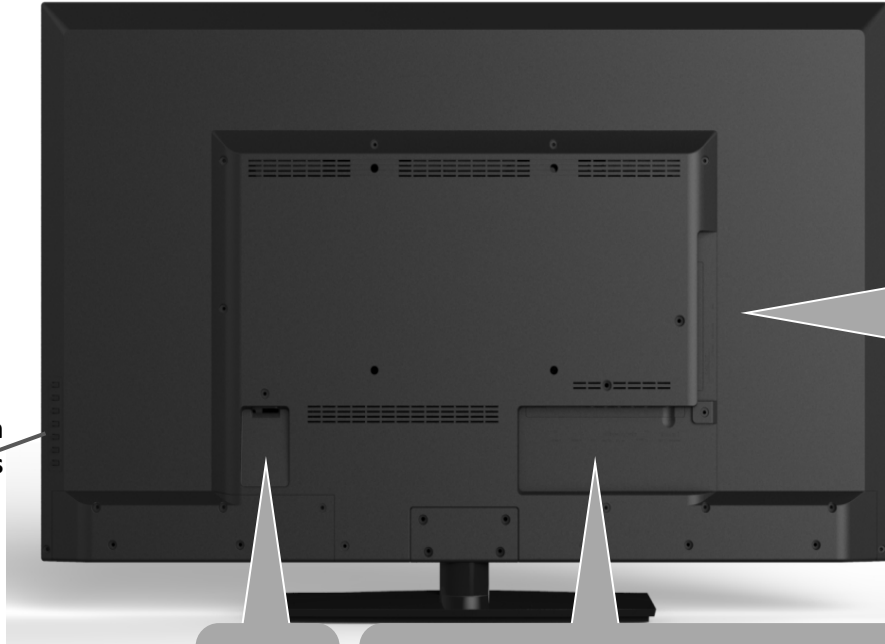

USB



HDMI / MHL
(*No charge supported while TV is OFF.)



Digital Optical Out



Audio Out



AC Power



HDMI-1



HDMI-2



Component/
Video Input



Audio Input/
Music Port



Antenna
Input

INSTALLING BASE AND BATTERIES

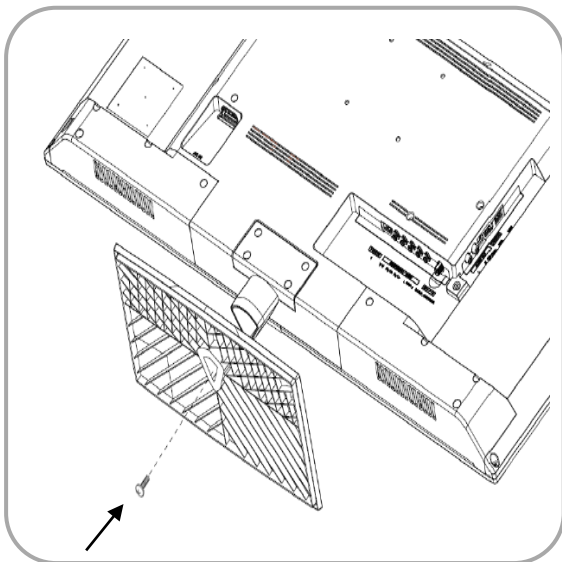

*EM32FL

*EM39FT

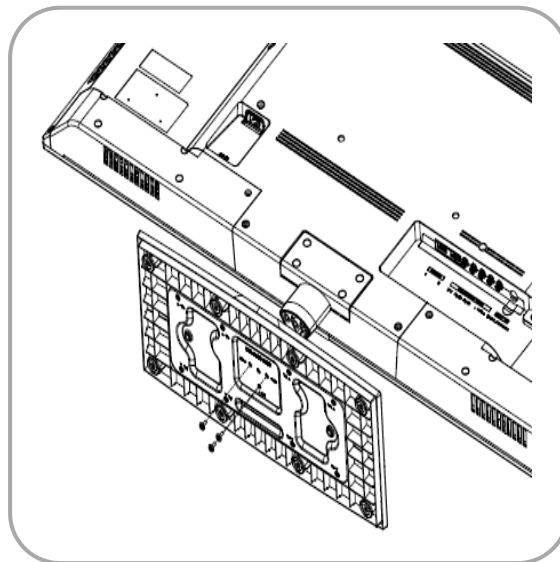

*EM42FT

*EM48FT



*Carefully place TV face down on a flat and clean surface. It is recommended to place the TV cover or protection sheet between the TV and the flat surface

*Attach base to TV unit and fasten with screw provided

*Images shown here are only for illustration purpose.

INSTALLING BASE AND BATTERIES

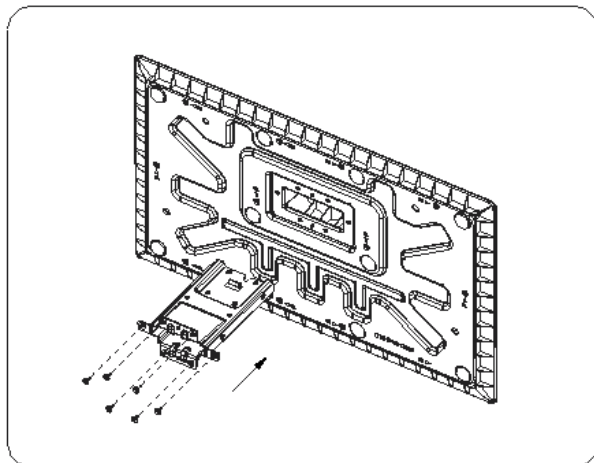

*EM55FT

*EM65FT

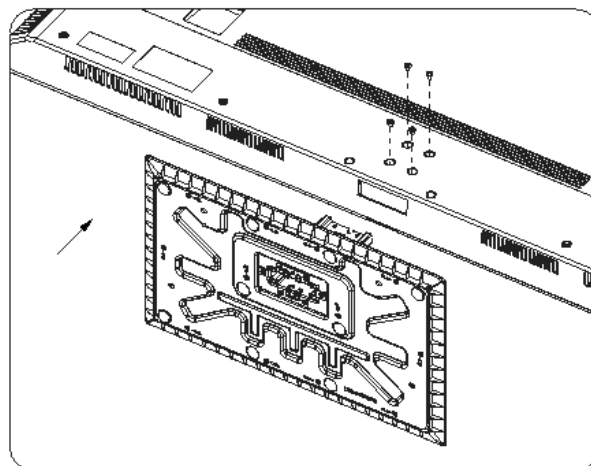

Carefully place TV face down on a flat and clean surface. It is recommended to place the TV cover or protection sheet between the TV and the flat surface
Attach base to TV unit and fasten with screw provided

*Images shown here are only for illustration purpose.

INSTALLING BASE AND BATTERIES

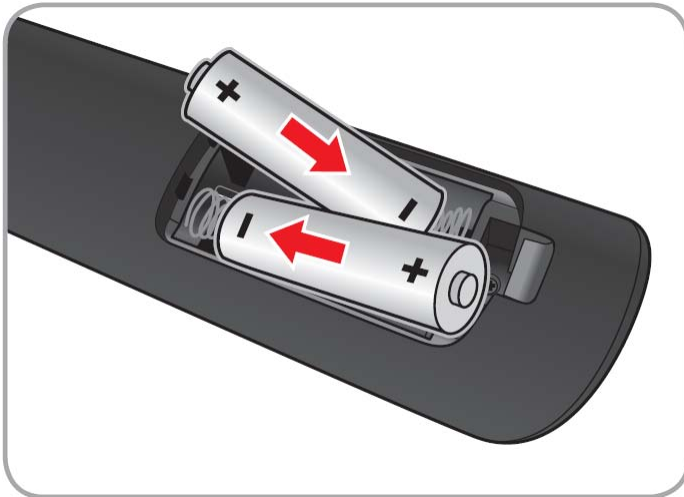

Be sure to follow correct polarity.

Do NOT combine a used battery with a new one

Do NOT combine rechargeable battery with a non-rechargeable battery (e.g. Alkaline or Carbon-zinc)

CONNECTING TV AND DEVICES

Connect to Power



Connect to DTV / Cable / Antenna

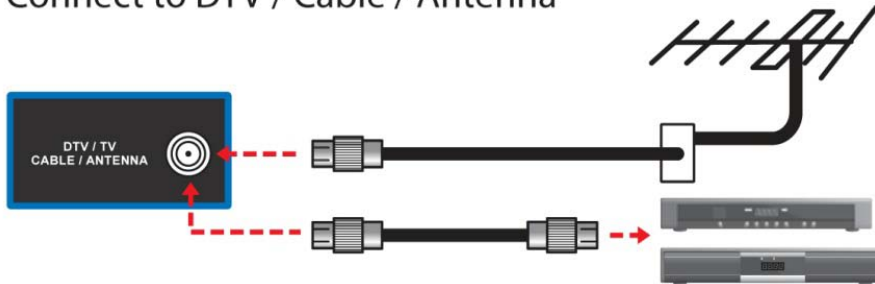

Antenna Cable is not included

Connect to External Music Players

Music Port

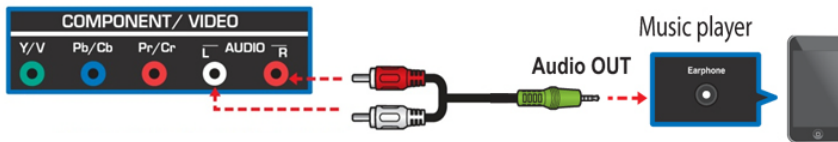

Audio cable is not included

CONNECTING TV AND DEVICES

Connect to HD Devices (Bluray Player, Cable or Satellite, Game Console)

HDMI



Component

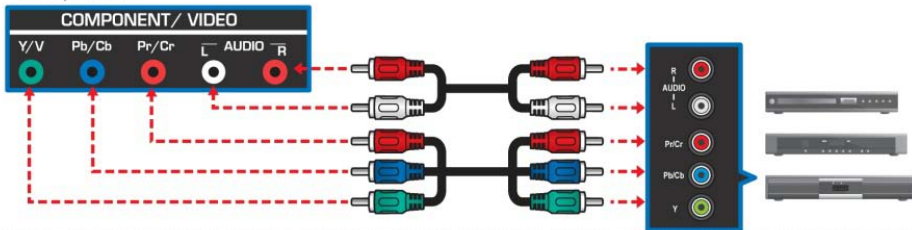

Composite

*Please Note, the Composite video input is shared with the component.

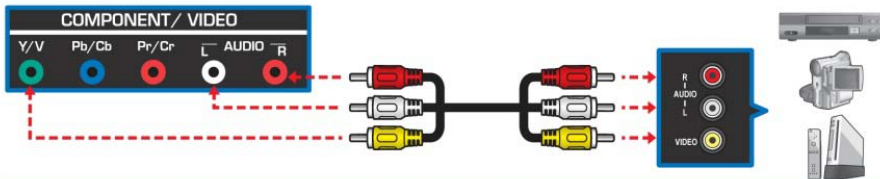

HDMI, AV Cables are not included

Connect to External Speakers/Amplifiers

Digital connection



Optical cable is not included

CONNECTING TV AND DEVICES

Connect to USB

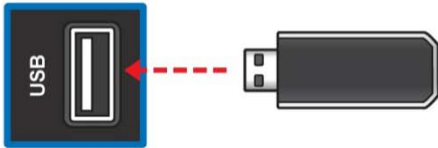

USB drive is not included

FIRST TIME SETUP

The **Setup Wizard** appears when you turn on the TV for the first time.

Follow the TV on-screen instruction and use the remote to choose

- **Menu language**
- **TV mode**
- **Time Zone**
- **Channel Scan**

Make sure batteries are inserted to the TV remote control



You can also run the **Setup Wizard** at any time, by choosing
MENU > SETUP > SETUP WIZARD

*Images shown here are only for illustration purpose.

Finish

Initial Setup has finished, please press "OK" to exit Setup Wizard.

OK

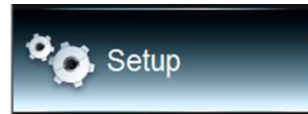

Name Input
CEC Settings
Menu Language English
Time & Local Settings
Parental Control
Power Indicator On
Setup Wizard
System Information
Reset All Settings

TROUBLESHOOTING

Problem	Solution
No Power	<ul style="list-style-type: none">• Make sure the power cord is plugged in.• The power is off; press Power button to turn on the TV.• Try another outlet.• Unplug the unit for an hour, and then plug it back in.
Poor or No Sound	<ul style="list-style-type: none">• Press the VOL Up button on the remote control or adjust volume using the Power/Multi-Function button on TV (see page 6 for details).• Press MUTE button on the remote control to ensure mute is not on.• The channel or cable TV broadcast is experiencing problems. Tune to another channel.• Check the TV audio settings and possible sources of interference.
Poor or No Picture	<ul style="list-style-type: none">• The channel or cable TV is experiencing problems. Tune to another channel.• Make sure that channels are set into memory.• Check the antenna or cable TV connections.• Check for possible sources of interference.
Poor Reception on Some Channels	<ul style="list-style-type: none">• The channel or cable TV broadcast is experiencing problems. Tune to another channel.• Make sure that channels are set into memory.• The network signal is weak. Adjust the antenna to receive a better reception• Check for possible sources of interference.
The Remote Control does not work	<ul style="list-style-type: none">• Batteries may be weak, dead, or inserted incorrectly.• Point the remote control directly at the IR sensor on the TV with an angle of 35 degrees.• Remove any obstacles between the remote control and the TV.• Remote control is out of range. Move closer to the TV.
TV Shuts Off	<ul style="list-style-type: none">• Sleep timer is set.• Power is interrupted.
No CATV Reception	<ul style="list-style-type: none">• Check all cable TV connections.• Set the TV Mode in Channel menu.
Closed Caption is not activated	<ul style="list-style-type: none">• The channel/program is not a closed caption broadcast. Try another channel.• Enable Closed Caption in the Menu.

LIMITED WARRANTY

On Parts and Labor

This Limited Warranty covers units that are purchased as new and in the United States Only. This Product is manufactured, distributed, and warranted by AmTRAN Video Corporation (hereinafter known as “Warrantor”) under brand license by JVC KENWOOD Corporation. The Warrantor provides a warranty to the original purchaser of a new Product against defects in materials and workmanship for a period of one (1) year of non-commercial usage and ninety (90) days of commercial use. If a Product covered by this warranty is determined to be defective within the warranty period, the Warrantor will either repair or replace the Product at its sole option and discretion.

To obtain warranty service, contact Technical Support:

Visit the Web Site: <http://jvc-tv.com/support>

Or call our Customer Support and Service Center **1-855-868-1928**

PRE-AUTHORIZATION MUST BE OBTAINED BEFORE SENDING ANY PRODUCT TO A DESIGNATED SERVICE CENTER.

Proof of purchase in the form of a purchase receipt or copy thereof is required to show that a Product is within the warranty period.

Parts and Labor

There will be no charge for parts or labor during the warranty period.

Replacement parts and Products may be new or recertified at the Warrantor’s option and sole discretion. Replacement parts and Products are warranted for the remaining portion of the original warranty or for ninety (90) days from warranty service or replacement, whichever is longer.

Types of Service

Defective Products must be sent to the designated service center to obtain warranty service. The Warrantor is not responsible for the transportation costs to the service center, but will cover the costs for return shipping to the customer.

PRE-AUTHORIZATION IS REQUIRED BEFORE SENDING ANY PRODUCT TO A DESIGNATED SERVICE CENTER FOR WARRANTY SERVICE.

Product returned to designated service centers must either utilize the original carton box and shipping material or packaging that affords an equal degree of protection. Technical Support will provide instructions for packing and shipping the Product to the designated service center.

Limitations and Exclusions

The Warrantor’s one-year limited warranty only covers defects in materials and workmanship. This warranty does not cover product issues caused by any other reason including, but not limited to, cosmetic damage, normal wear and tear, improper operation, improper voltage supply or power surges, signal issues, damages from shipping, acts of God, any type of customer misuse, modifications or adjustments, as well as installation and setup issues or any repairs attempted by anyone other than by a authorized service center. Products with unreadable or removed serial numbers, or requiring routine maintenance are not covered. This one-year limited warranty does not cover Products that are sold “As-Is”, “Open Box”, “FACTORY RECERTIFIED”, or by a non-authorized reseller.

THERE ARE NO EXPRESS WARRANTIES OTHER THAN THOSE LISTED OR DESCRIBED ABOVE. ANY IMPLIED WARRANTIES, INCLUDING ANY IMPLIED WARRANTY OF MERCHANTABILITY AND FITNESS FOR A PARTICULAR PURPOSE, SHALL BE LIMITED IN DURATION TO THE PERIOD OF TIME SET FORTH ABOVE. THE WARRANTOR’S TOTAL LIABILITY FOR ANY AND ALL LOSSES AND DAMAGES RESULTING FROM ANY CAUSE WHATSOEVER

INCLUDING WARRANTOR’S NEGLIGENCE, ALLEGED DAMAGE, OR DEFECTIVE GOODS, WHETHER SUCH DEFECTS ARE DISCOVERABLE OR LATENT, SHALL IN NO EVENT EXCEED THE PURCHASE PRICE OF THE PRODUCT. THE WARRANTOR SHALL NOT BE RESPONSIBLE FOR LOSS OF USE, LOSS OF INFORMATION OR DATA, COMMERCIAL LOSS, LOST REVENUE OR LOST PROFITS, OR OTHER INCIDENTAL OR CONSEQUENTIAL DAMAGES. SOME STATES DO NOT ALLOW LIMITATIONS ON HOW LONG AN IMPLIED WARRANTY LASTS OR THE EXCLUSION OF INCIDENTAL OR CONSEQUENTIAL DAMAGES, SO THE ABOVE LIMITATIONS OR EXCLUSIONS MAY NOT APPLY TO YOU. THIS WARRANTY GIVES YOU SPECIFIC LEGAL RIGHTS, AND YOU MAY ALSO HAVE OTHER RIGHTS, WHICH VARY FROM STATE TO STATE. THIS WARRANTY IS SUBJECT TO CHANGE WITHOUT NOTICE. CHECK TV.JVC.COM FOR THE MOST CURRENT VERSION.

LIMITED WARRANTY

PERSONAL DATA

If your Product is capable of storing personal data and other information, all contents and information will be deleted in the course of some in-home, and all ship-in, warranty service. If this occurs, your Product will be restored to you configured as originally purchased. You will be responsible for restoring all applicable data and passwords. Recovery and reinstallation of User data is not covered under this Limited Warranty. In order to protect your personal information, we recommend that you always clear all personal information from the Product before it is serviced, regardless of the servicer.

Important Open Source Software Notice

Some JVC device may contain free software which is based on the license granted under the GNU General Public License and Lesser General Public License (hereinafter “GPL/LGPL”) that are subject to the GPL2.0/LGPL2.1 You may use, modify, or distribute only if you agree to all of the terms and conditions of the GPL/LGPL. For more details on the list of JVC devices with open source software, please visit <http://jvc-tv.com/support>

Please note that any software component developed or created independently by AmTRAN Video Corporation shall not be subject to “GPL/LGPL” requirement for provision of the source code. Users are urged to read the details for the relevant license carefully before using the software component covered by “GPL/LGPL.”

You can obtain a copy of the GPL/LGPL license from <http://www.gnu.org/licenses/gpl> and <http://www.gnu.org/licenses/lgpl>. Please note that we are unable to answer any inquiry relating to the contents, etc of the source code.

Permission is hereby granted, free of charge, to any person obtaining a copy of any such software and associated documentation files (the “Open Source Software”), to deal in the Open Source Software without restriction including without limitation the rights to use, copy, modify, merge, publish, distribute, sublicense, and/or sell copies of the Open Source Software, and to permit persons to whom the Open Source Software is furnished to do so, subject to the following conditions:

THE SOFTWARE IS PROVIDED “AS IS”, WITHOUT WARRANTY OF ANY KIND, EXPRESS OR IMPLIED, INCLUDING BUT NOT LIMITED TO THE WARRANTIES OF MERCHANTABILITY, FITNESS FOR A PARTICULAR PURPOSE AND NON-INFRINGEMENT, IN NO EVENT SHALL THE AUTHORS OR COPYRIGHT HOLDERS BE LIABLE FOR ANY CLAIM, DAMAGES OR OTHER LIABILITY, WHETHER IN AN ACTION OF CONTRACT, TORT OR OTHERWISE, ARISING FROM, OUT OF OR IN CONNECTION WITH THE SOFTWARE OR THE USE OR OTHER DEALINGS IN THE SOFTWARE.

REGULATORY STATEMENT

This device complies with Part 15 of the FCC Rules. Operation is subject to the following two conditions: (1) this device may not cause harmful interference, and (2) this device must accept any interference received, including interference that may cause undesired operation. Note: This equipment has been tested and found to comply with the limits for a Class B digital device, pursuant to Part 15 of the FCC Rules. These limits are designed to provide reasonable protection against harmful interference in a residential installation. This equipment generates, uses, and can radiate radio frequency energy and, if not installed and used in accordance with the instructions, may cause harmful interference to radio communications.

However, there is no guarantee that interference will not occur in a particular installation. If this equipment does cause harmful interference to radio or television reception, which can be determined by turning the equipment off and on, the user is encouraged to try to correct the interference by one or more of the following measures:

Reorient or relocate the receiving antenna.

Increase the separation between the equipment and receiver.

Connect the equipment into an outlet on a circuit different from that to which the receiver is connected

Consult the dealer or an experienced radio/TV technician for help.

CAUTION:

Changes or modifications not expressly approved by the party responsible for compliance with the FCC Rules could void the user’s authority to operate this equipment.

Responsible Party: AmTRAN Video Corporation

Address: 9 Goddard, Irvine, CA 92618, USA

Telephone No; 949-336 6633

Required Marking Location

The rating sheet and the safety caution are on the rear of the unit.

TV SERIAL NUMBER

Copy TV serial number here for quick future reference

Serial Number:

Model Number:

Serial and Model numbers can be found on the safety label located on the back of the TV.

EXAMPLES



- *EM32FL
- *EM42FT
- *EM48FT
- *EM55FT
- *EM65FT



- *EM39FT

*Images shown here are only for illustration purpose.

We Are Here To Help!

Call our highly trained support team at

1 - 855 - 868 - 1928

We can help you with

- Damaged Package
- Missing Parts
- Technical Support

Or visit

<http://jvc-tv.com>



JVC