

Assembly Instructions

Caution : You must read this before you proceed

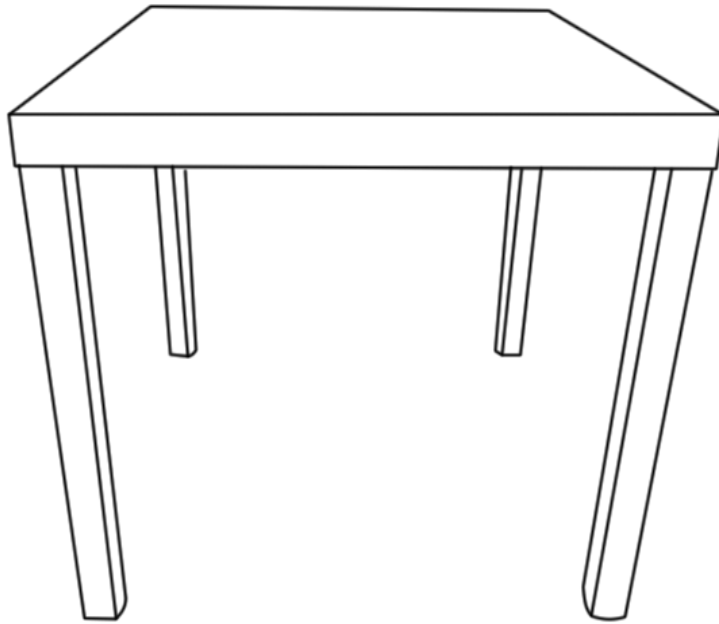



Table

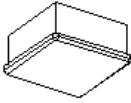
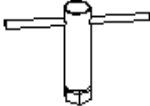

Parts List

Label	Picture	Description	QTY
A	A line drawing of a rectangular table top, shown from a perspective view, highlighting its thickness and flat surface.	Table Top	1PC
B	A line drawing of a single table leg, shown from a perspective view, highlighting its tapered shape and small notch at the bottom.	Leg	4PCS

Hardware

Label	Picture	Description	QTY
1		Iron Bar(M10)	4PCS
2		Leg Cap	4PCS
3		Box Wrench	1PC
4		Nut (M10)	5PCS
5		Spring washer	5PCS
6		Washer	5PCS

Assembly Preparation

Before Beginning Assembly:

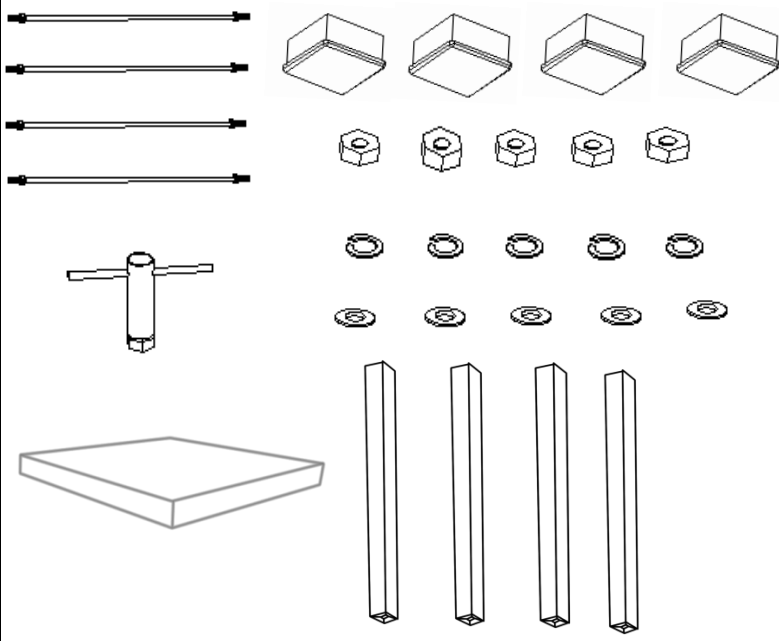

The diagram illustrates the hardware components required for assembly preparation. It includes four iron bars, four leg caps, one box wrench, five nuts, five spring washers, five washers, and four iron bars.



- Read instructions, cover to cover-



- Have 2 adults on hand for assembly-



- Do not assemble on flooring or carpet-



- Assemble on a clean non-marring surface (packing foam)-



- Save all packaging until finished-

Assembly Steps

Step 1

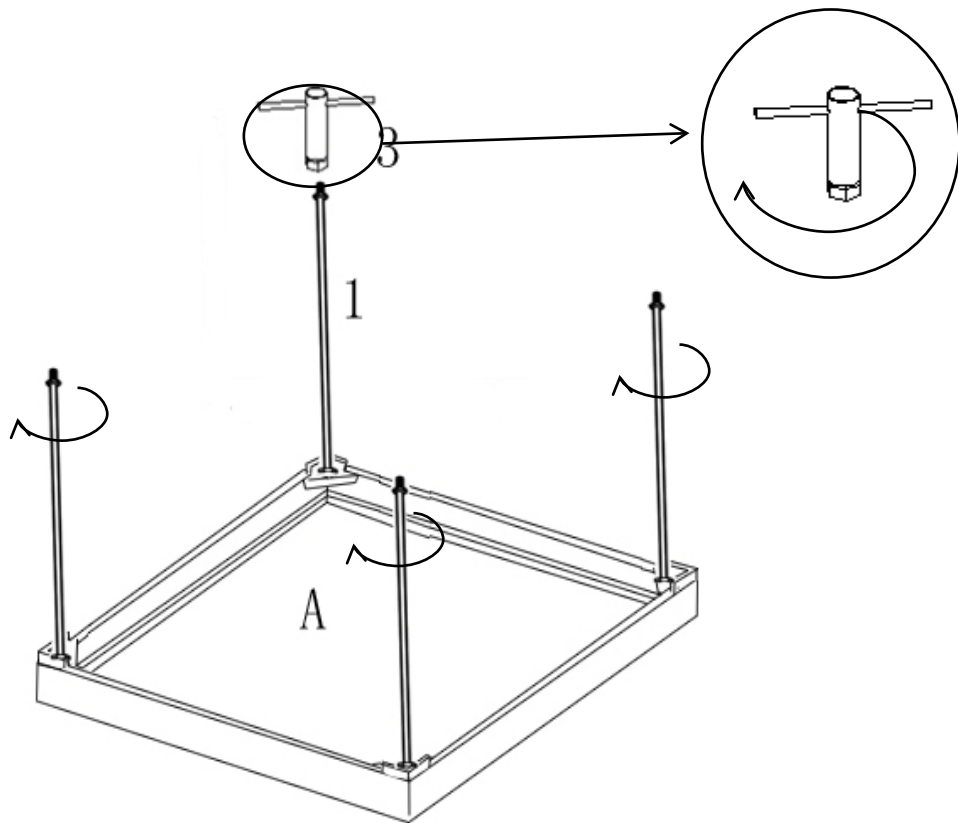

Position the Table Top(A) as shown above, on a clean, non-marring surface.

Insert Iron Bar(1) into mounting positions at corners of table.

Turn in Iron Bar (1) with Box Wrench(3).

Repeat Step 1 with the remaining three Iron Bars(1).

Caution: Fully tighten all Iron Bars (1).

Step 2

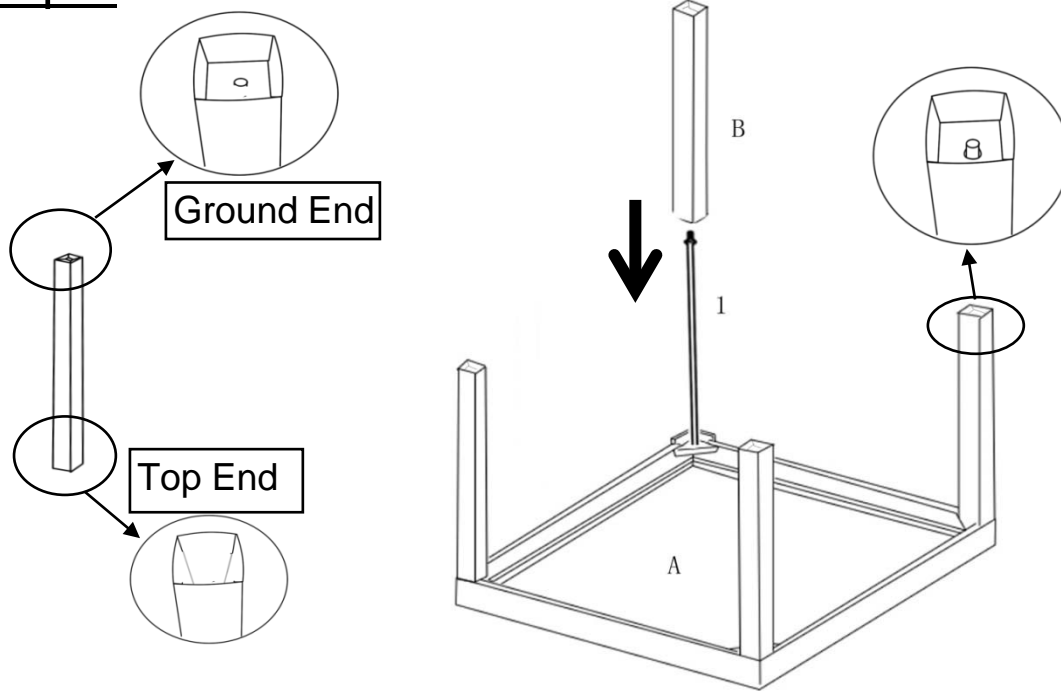

Turn the Leg(B) top end facing downwards.

Place Leg(B) into the Iron Bar(1).

Align the nut hole and slide the Leg through till the Iron Bar(1), becomes visible at the Ground End of the Leg.

Caution: The hole is on the ground end of the Leg(B).

Step3

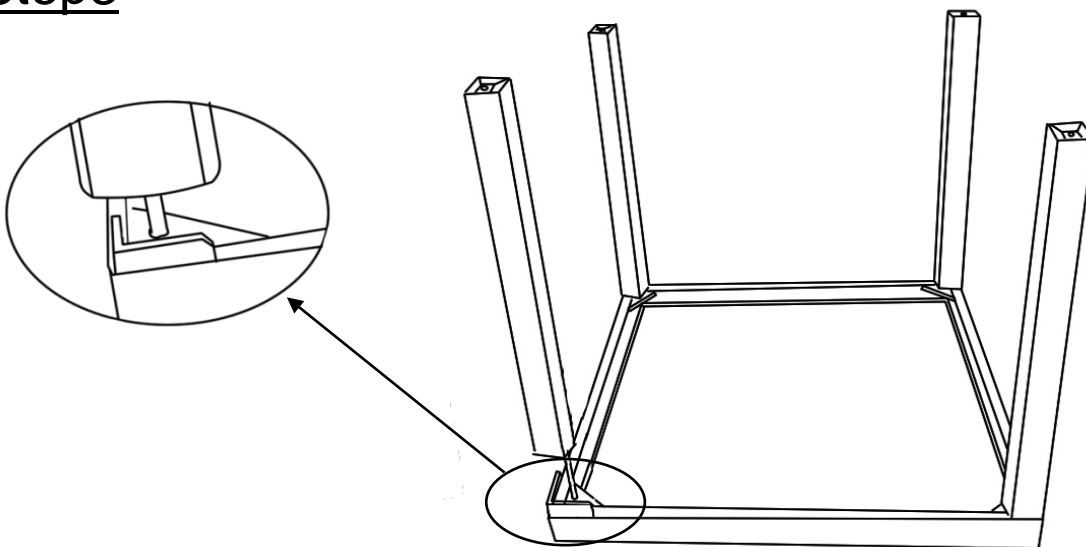

Hold and align the Leg(B), till the Column Leg squares to the table corner.

Step 4

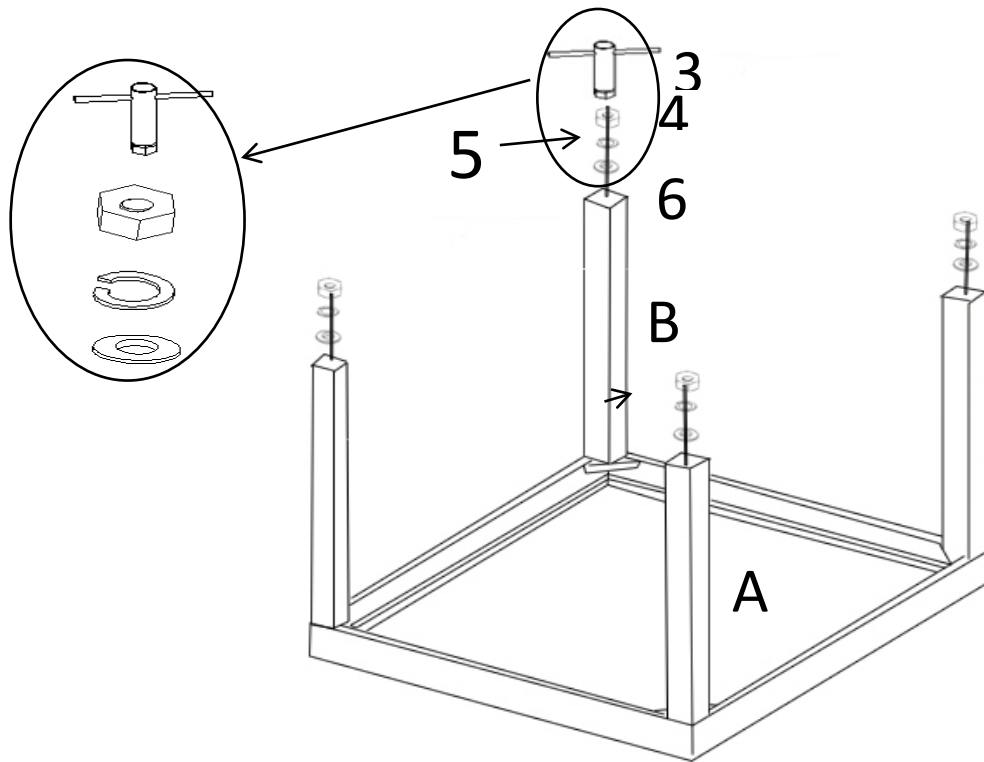

Put the Spring Washers(6 & 5) and Nut(4) into the **Iron Bar(1)**.
Drive in using the **Box Wrench(3)**, **loosely tighten the bolts**.
Repeat the same to the other 3 legs.

Step 5

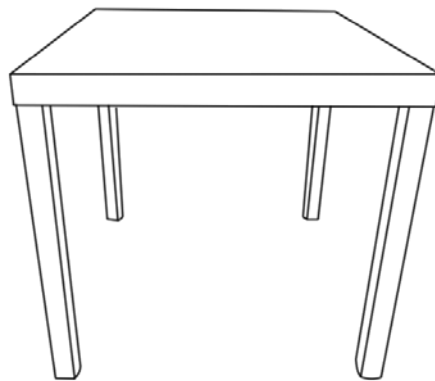

Turn the table right side up.
Check for stability.

Then, turn table upside down and proceed to **FULLY TIGHTEN** the bolts.

Note : DO NOT fully tighten a BOLT in one go and then move on to the next.
Rather, In a sequential manner, gradually tighten each Bolt until all bolts are evenly secured. This methodology will ensure maximum evenness once all Bolts are fully tightened.

Step 6

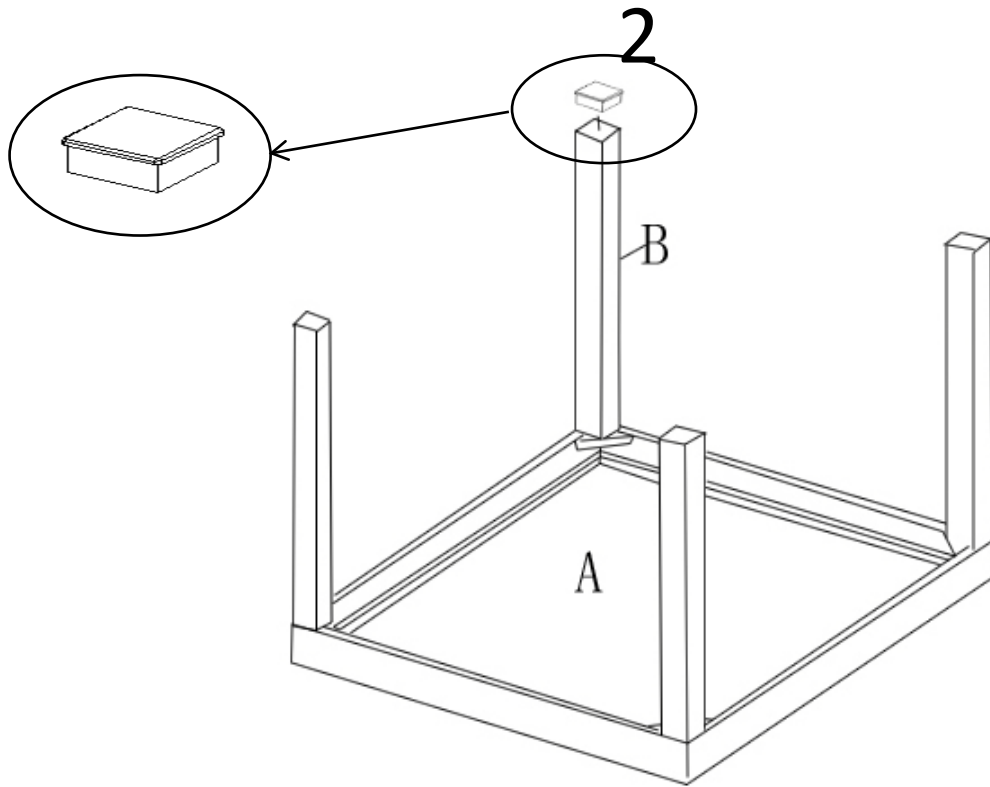

Attach Leg Cap(2) to the ground end of the Leg (B).
Repeat Step 4 with the remaining three Legs(B).

Step 7

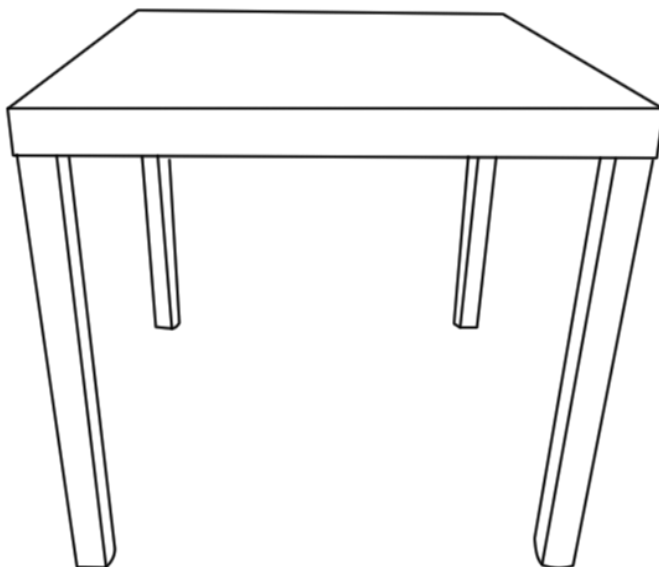

Turn the table right side up.
Your Table is ready for use.

Care & Maintenance



- Do not put hot items directly on furniture surface.



- Do not clean furniture with harsh cleansers or polish.



- To obtain the longest lifespan of your outdoor products, minimizing exposure to direct sunlight is recommended.



- Children should not climb or jump on the furniture.



- Do not write on furniture without a padded barrier to protect the surface.



- To obtain the longest lifespan of your outdoor products, avoid extended and lengthy exposure to rain, snow, and direct sunshine. Whenever possible cover the product and /or place under patio or awnings.



- Not for commercial use. For residential use only .



- Stains may be removed with mild soap solution and damp cloth.



- Keep away from sources of ignition.



- Dust and pick-up spills using a clean, non-colored, lint-free cloth .